

Zamus Star Endmill

고경도 가공용 자무스 스타 엔드밀

제품설명

- 열처리강 및 합금강, 탄소강 등의 고경도 피삭재(추천 : HRc 50~70)의 고속 가공에 적합
- 롱 넥, 리브, 테이퍼 넥 등의 재원으로 다양한 형상의 가공 프로세스에 적합

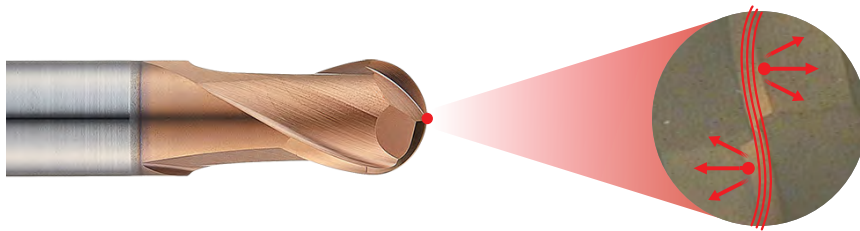

제품특징

- 초미립자 소재를 사용하여 공구의 인선 내마모성 향상
- AlTiN 코팅 적용으로 고속 가공 시 날부의 고온 내산화성, 경도 유지
- 고경도 피삭재의 고속 가공에 적합한 인선부 설계로 안정적인 성능

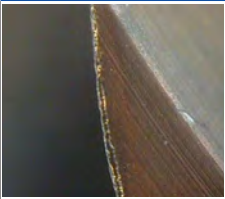
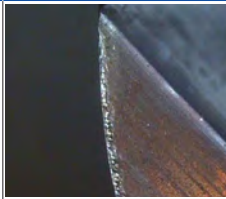

- S형상 적용으로 절삭 부하가 분산되어 안정적인 공구 수명
- 반경공차 ±0.005mm 으로 가공 정밀도 향상

절삭시험결과

구분	Zamus Star	타사	구분	Zamus Star	타사
날			코너 라디우스		
· 테스트 공구 : DB702120 · 피삭재 : SKD11 열처리 / rpm : 5,950 / feed : 1,870 / ap : 0.25 / ae : 0.6			· 테스트 공구 : ZS2041001032 · 피삭재 : SKD11 열처리 / rpm : 5,550 / feed : 1,100 / ap : 10 / ae : 0.5		



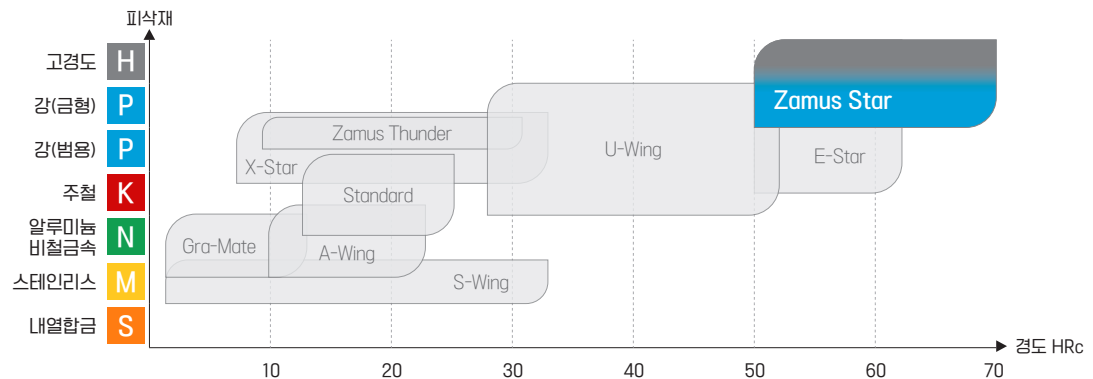











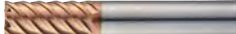





적용영역

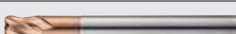
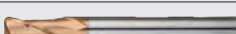
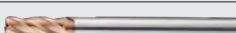

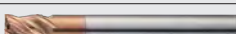
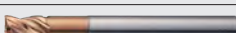
Zamus Star Endmill

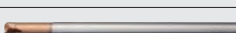
고경도 가공용 자무스 스타 엔드밀

목차

구분		제품번호	사진	품명	공구직경(DC)		페이지
형상	날수				최소	최대	
스퀘어	2날	ZE702		2날 넥 스퀘어 엔드밀	0.1	20	28
	4날	ZE704		4날 넥 스퀘어 엔드밀	1	20	29
	2날	ZE712		2날 스퀘어 엔드밀	1	12	30
	4날	ZE714		4날 스퀘어 엔드밀	1	12	31
	6날	ZE716		6날 스퀘어 엔드밀	6	20	32
	4날&6날	ZE724(6)		4&6날 넥 스퀘어 엔드밀	1	12	33
	4날	ZS124		4날 스퀘어 엔드밀	2	12	34
	2날	ZSLNS20		2날 롱 넥 스퀘어 엔드밀	0.1	5	35
4날	ZSLNS40		4날 롱 넥 스퀘어 엔드밀	1	5	40	
라디우스	2날	ZR702		2날 넥 라디우스 엔드밀	1	12	43
	4날	ZR704		4날 넥 라디우스 엔드밀	1	12	49
	6날	ZR706		6날 넥 라디우스 엔드밀	6	12	53
	4날	ZR714		4날 라디우스 엔드밀	3	12	54
	4날	ZR724		4날 넥 라디우스 엔드밀	6	12	55
	2날	ZR732		2날 롱 샹크 라디우스 엔드밀	1	12	56
	4날	ZR734		4날 롱 샹크 라디우스 엔드밀	1	12	58
	6날	ZR736		6날 라디우스 엔드밀	6	12	60
	4날	ZS1(2)04		4날 넥 라디우스 엔드밀	1	12	61
	4날	ZS204		4날 넥 라디우스 엔드밀	2	12	62
	2날	ZSLNR20		2날 롱 넥 라디우스 엔드밀	0.2	3	64
	2날	ZSTNR20		2날 테이퍼 넥 라디우스 엔드밀	0.2	3	68
	4날	ZSPM4		4날 고이송용 넥 라디우스 엔드밀	3	12	71
볼	2날	DB702		2날 넥 볼 엔드밀	0.1	12	72
	3날	DB703		3날 넥 볼 엔드밀	2.5	12	73
	2날	DB712		2날 볼 엔드밀	1	12	74

구분		제품번호	사진	품명	공구직경(DC)		페이지
형상	날수				최소	최대	
볼	4날	DB734		4날 15도 헬릭스 볼 엔드밀	2	10	75
	2날	ZSLNB20		2날 롱 넥 볼 엔드밀	0.1	5	76
	2날	ZSTNB20		2날 테이퍼 넥 볼 엔드밀	0.2	10	81
	3날	ZSTNB30		3날 테이퍼 넥 볼 엔드밀	2	5	86

품번체계

*정수로 표현되는 경우 소수점 이하는 생략합니다.

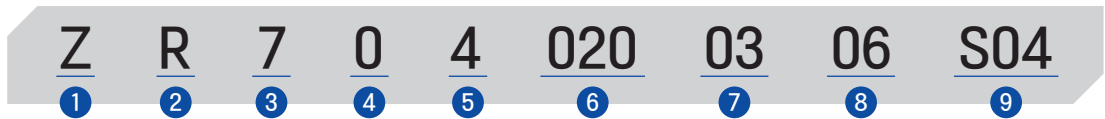

① 시리즈명	② 형상	③ 등급	④ 길이, 자루타입	⑤ 날수	⑥ 날경	⑦ 코너R	⑧ 유효장	⑨ 자루경
Z : Zamus	E : 스퀘어	7 : Grade	0 : 넥	2 : 2날	0.05	0.05	자세한 내용은 카탈로그 참고	4
D : Dynamic	R : 래디우스		1 : 스트레이트, 넥	3 : 3날	~	~		~
ZS : Zamus Star	B : 볼		2 : 롱 넥	4 : 4날	20	3		20
	LNS : 롱 넥 스퀘어		3 : 롱 샹크	5 : 5날				
	LNR : 롱 넥 래디우스							
	LNB : 롱 넥 볼							
	PM : 파워 밀							

EX) 4날 / 날경 ϕ 2 / 코너R 0.3 / 유효장 6mm / 자루경 4 / 70급 코너 래디우스 넥 타입 자무스 엔드밀

ZE702 2날 넥 스퀘어 엔드밀

Endmill

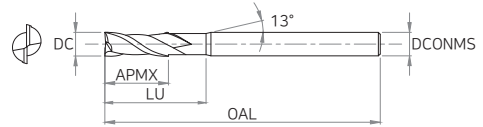
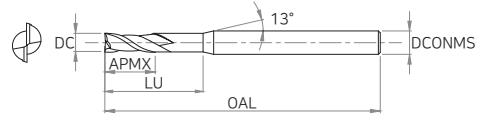

▶ 제품허용공차

날경(DC)		자루경
~ Ø6	0 ~ -0.012	h5
Ø8 ~ Ø20	0 ~ -0.015	

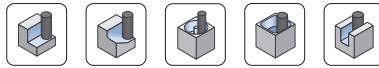

CARBIDE AITIN 30° HELIX 절삭조건 P.607

품목코드	DC	APMX	LU	OAL	DCONMS	품목코드	DC	APMX	LU	OAL	DCONMS
	날경	날장	유효장	전장	자루경		날경	날장	유효장	전장	자루경
ZE702 001	0.1	0.2	-	40	4	ZE702 020	2	3	6	40	6
ZE702 002	0.2	0.4	-	40	4	ZE702 025	2.5	4	6	40	6
ZE702 003	0.3	0.5	-	40	4	ZE702 030	3	4	7	45	6
ZE702 004	0.4	0.7	-	40	4	ZE702 035	3.5	6	9	45	6
ZE702 005	0.5	1	-	40	4	ZE702 040	4	6	9	45	6
ZE702 006	0.6	1.2	-	40	4	ZE702 045	4.5	6	10	45	6
ZE702 007	0.7	1.4	-	40	4	ZE702 050	5	6	11	50	6
ZE702 008	0.8	1.6	-	40	4	ZE702 060	6	7	14	50	6
ZE702 009	0.9	2	-	40	4	ZE702 080	8	9	18	60	8
ZE702 010 S4	1	1.5	-	40	4	ZE702 100	10	12	25	75	10
ZE702 010	1	1.5	-	40	6	ZE702 120	12	15	30	75	12
ZE702 015	1.5	2.2	-	40	6	ZE702 160	16	18	38	90	16
ZE702 020 S4	2	3	6	40	4	ZE702 200	20	24	45	100	20

▶ 적용 피삭재

○ : 적합 ◎ : 매우 적합

H		P			K	N			M	S
열처리강		탄소강	합금강	프리하든강	주철	동	흑연	알루미늄	스테인리스	내열합금
SKD61 ~HRc55	SKD11 HRc55~	~HB225	HB225 ~325	HRc30~50	~FCD500					
◎	◎		○	○						

ZE704 4날 넥 스퀘어 엔드밀

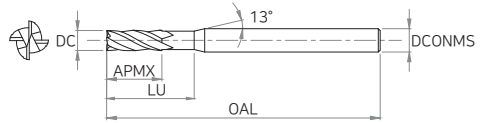
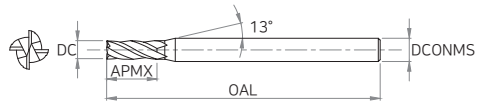

▶ 제품허용공차

날경(DC)		자루경
~ Ø6	0 ~ -0.012	h5
Ø8 ~ Ø20	0 ~ -0.015	

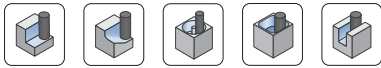

품목코드	DC	APMX	LU	OAL	DCONMS
	날경	날장	유효장	전장	자루경
ZE704 010 S4	1	1.5	-	40	4
ZE704 010	1	1.5	-	40	6
ZE704 015	1.5	2.2	-	40	6
ZE704 020 S4	2	3	6	40	4
ZE704 020	2	3	6	40	6
ZE704 025	2.5	4	6	40	6
ZE704 030	3	4	7	45	6
ZE704 035	3.5	5	9	45	6
ZE704 040	4	5	9	45	6
ZE704 045	4.5	6	10	45	6
ZE704 050	5	6	11	50	6
ZE704 060	6	7	14	50	6
ZE704 080	8	9	18	60	8
ZE704 100	10	12	25	75	10
ZE704 120	12	15	30	75	12
ZE704 160	16	18	38	90	16
ZE704 200	20	24	45	100	20

▶ 적용 피삭재

○ : 적합 ◎ : 매우 적합

H		P			K	N			M	S
열처리강		탄소강	합금강	프리하트강	주철	동	흑연	알루미늄	스테인리스	내열합금
SKD61 ~HRc55	SKD11 HRc55~	~HB225	HB225 ~325	HRc30~50	~FCD500					
◎	◎		○	○						

ZE712 2날 스퀘어 엔드밀

Endmill

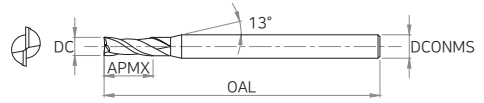

Zamus Star

▶ 제품허용공차

날경(DC)		자루경
전 규격	0 ~ -0.02	h5

E-Star

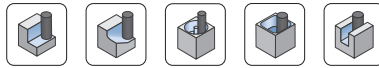

U-Wing

Zamus Thunder

품목코드	DC	APMX	OAL	DCONMS
	날경	날장	전장	자루경
ZE712 010-02	1	2	40	6
ZE712 010	1	3	40	6
ZE712 010-04	1	4	40	6
ZE712 012	1.2	3	40	6
ZE712 015	1.5	4	40	6
ZE712 015-06	1.5	6	40	6
ZE712 015-08	1.5	8	40	6
ZE712 020	2	5	40	6
ZE712 020-08	2	8	40	6
ZE712 020-10	2	10	50	6
ZE712 025	2.5	6	40	6
ZE712 030	3	8	45	6
ZE712 030-10	3	10	50	6
ZE712 030-12	3	12	50	6
ZE712 035	3.5	10	45	6

품목코드	DC	APMX	OAL	DCONMS
	날경	날장	전장	자루경
ZE712 040	4	10	45	6
ZE712 040-12	4	12	50	6
ZE712 040-16	4	16	60	6
ZE712 045	4.5	11	45	6
ZE712 050	5	13	50	6
ZE712 055	5.5	13	50	6
ZE712 060	6	13	50	6
ZE712 060-15	6	15	60	6
ZE712 065	6.5	16	60	8
ZE712 070	7	18	60	8
ZE712 080	8	19	60	8
ZE712 100	10	22	70	10
ZE712 120	12	26	75	12
ZE712 120-30	12	30	75	12

S-Wing

A-Wing

Standard

Copper -Mate

Gra -Mate

▶ 적용 피삭재

○ : 적합 ◎ : 매우 적합

H		P			K	N			M	S
열처리강		탄소강	합금강	프리하든강	주철	동	흑연	알루미늄	스테인리스	내열합금
SKD61 ~HRc55	SKD11 HRc55~	~HB225	HB225 ~325	HRc30~50	~FCD500					
◎	◎		○	○						

ZE714 4날 스퀘어 엔드밀

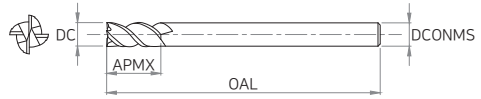
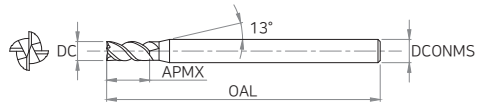

▶ 제품허용공차

날경(DC)		자루경
전 규격	0 ~ -0.02	h5

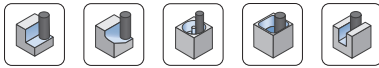

품목코드	DC	APMX	OAL	DCONMS
	날경	날장	전장	자루경
ZE714 010	1	2.5	40	6
ZE714 012	1.2	3	40	6
ZE714 015	1.5	4	40	6
ZE714 020	2	5	40	6
ZE714 025	2.5	6	40	6
ZE714 030	3	8	45	6
ZE714 035	3.5	9	45	6
ZE714 040	4	10	45	6
ZE714 050	5	13	50	6
ZE714 060	6	13	50	6
ZE714 060-15	6	15	60	6
ZE714 080	8	19	60	8
ZE714 100	10	22	70	10
ZE714 100-25	10	25	70	10
ZE714 120	12	26	75	12
ZE714 120-30	12	30	80	12

▶ 적용 피삭재

○ : 적합 ◎ : 매우 적합

H		P			K	N			M	S
열처리강		탄소강	합금강	프리하든강	주철	동	흑연	알루미늄	스테인리스	내열합금
SKD61 ~HRC55	SKD11 HRC55~	~HB225	HB225 ~325	HRC30~50	~FCD500					
◎	◎		○	○						

Endmill

Zamus Star

E-Star

U-Wing

Zamus Thunder

X-Star

S-Wing

A-Wing

Standard

Copper-Mate

Gra-Mate

ZE716 6날 스퀘어 엔드밀

Endmill

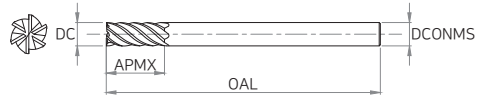
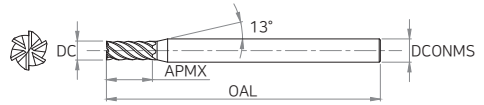

Zamus Star

E-Star

▶ 제품허용공차

날경(DC)		자루경
전 규격	0 ~ -0.02	h5

U-Wing

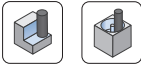

CARBIDE AITIN 50° HELIX 6 절삭조건 P.608

Zamus Thunder

품목코드	DC	APMX	OAL	DCONMS
	날경	날장	전장	자루경
ZE716 060	6	13	50	6
ZE716 080	8	18	60	8
ZE716 100	10	22	70	10
ZE716 120	12	16	75	12
ZE716 160	16	35	90	16
ZE716 200	20	44	100	20

X-Star

S-Wing

A-Wing

Standard

Copper -Mate

Gra -Mate

▶ 적용 피삭재

○ : 적합 ◎ : 매우 적합

H		P			K	N			M	S
열처리강		탄소강	합금강	프리하든강	주철	동	흑연	알루미늄	스테인리스	내열합금
SKD61 ~HRc55	SKD11 HRc55~	~HB225	HB225 ~325	HRc30~50	~FCD500					
◎	◎		○	○						

ZE724(6)

4&6날 뱁 스퀘어 엔드밀

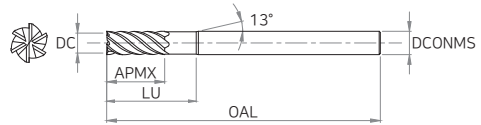
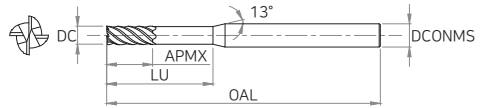

▶ 제품허용공차

날경(DC)		자루경
~ Ø6	0 ~ -0.012	
Ø8 ~ Ø12	0 ~ -0.015	h5

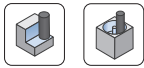

CARBIDE
AlTiN
4
6
45° HELIX NOF=4
60° HELIX NOF=6
절삭조건 P.608

품목코드	DC	APMX	LU	OAL	DCONMS	NOF
	날경	날장	유효장	전장	자루경	날수
ZE724 010	1	1.5	5	45	6	4
ZE724 015	1.5	2.2	6	45	6	4
ZE724 020	2	3	8	45	6	4
ZE724 030	3	4	9	50	6	4
ZE724 040	4	5	12	50	6	4
ZE724 050	5	6	15	50	6	4
ZE726 060	6	7	20	60	6	6
ZE726 080	8	9	25	70	8	6
ZE726 100	10	12	32	75	10	6
ZE726 120	12	15	38	80	12	6

▶ 적용 피삭재

○ : 적합 ◎ : 매우 적합

H		P			K	N			M	S
열처리강		탄소강	합금강	프리하든강	주철	동	흑연	알루미늄	스테인리스	내열합금
SKD61 ~HRc55	SKD11 HRc55~	~HB225	HB225 ~325	HRc30~50	~FCD500					
◎	◎		○	○						

- Endmill
- Zamus Star
- E-Star
- U-Wing
- Zamus Thunder
- X-Star
- S-Wing
- A-Wing
- Standard
- Copper-Mate
- Gra-Mate

ZS124 4날 스쿼어 엔드밀

Endmill

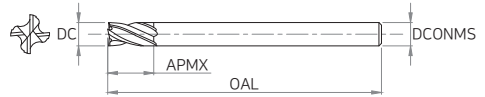
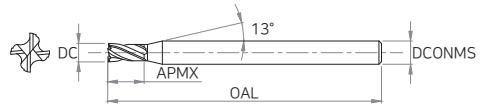

Zamus Star

E-Star

▶ 제품허용공차

날경(DC)		자루경
전 규격	0 ~ -0.02	h5

U-Wing

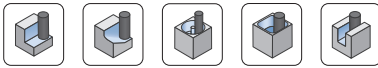

Zamus Thunder

품목코드	DC	APMX	OAL	DCONMS
	날경	날장	전장	자루경
ZS124 020	2	5	45	4
ZS124 030	3	8	45	6
ZS124 040	4	10	45	6
ZS124 060	6	16	50	6
ZS124 080	8	20	60	8
ZS124 100	10	25	75	10
ZS124 120	12	35	85	12

X-Star

S-Wing

A-Wing

Standard

Copper -Mate

Gra -Mate

▶ 적용 피삭재

○ : 적합 ◎ : 매우 적합

H		P			K	N			M	S
열처리강		탄소강	합금강	프리하든강	주철	동	흑연	알루미늄	스테인리스	내열합금
SKD61 ~HRC55	SKD11 HRc55~	~HB225	HB225 ~325	HRc30~50	~FCD500					
◎	◎		○	○						

ZSLNS20 2날 롱 넥 스퀘어 엔드밀

Endmill

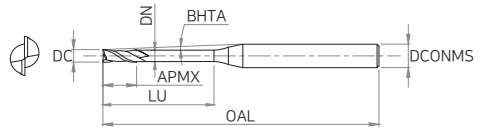

▶ 제품허용공차

날경(DC)		자루경
∅0.1 ~ ∅0.5	0 ~ -0.012	h5
∅0.6 ~ ∅5	0 ~ -0.015	

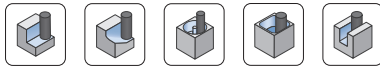

품목코드	DC	APMX	LU	DN	OAL	DCONMS	BHTA	가공물 구배각별 유효길이				
	날경	날장	유효장	유효경	전장	자루경	구배각	0.5°	1°	1.5°	2°	3°
ZSLNS20 01-0.3	0.1	0.15	0.3	0.08	45	4	11.6	0.4	0.4	0.5	0.5	0.5
ZSLNS20 01-0.5	0.1	0.15	0.5	0.08	45	4	11.4	0.6	0.7	0.7	0.7	0.8
ZSLNS20 01-1	0.1	0.15	1	0.08	45	4	10.9	1.2	1.2	1.2	1.3	1.4
ZSLNS20 02-0.5	0.2	0.3	0.5	0.17	50	4	11.3	1.2	1.3	1.5	1.7	2
ZSLNS20 02-1	0.2	0.3	1	0.17	50	4	10.8	1.7	1.9	2.2	2.4	2.7
ZSLNS20 02-1.5	0.2	0.3	1.5	0.17	50	4	10.3	2.3	2.5	2.8	3	3.4
ZSLNS20 03-1	0.3	0.45	1	0.27	50	4	10.8	1.7	1.9	2.2	2.4	2.7
ZSLNS20 03-1.5	0.3	0.45	1.5	0.27	50	4	10.3	2.3	2.5	2.8	3	3.4
ZSLNS20 03-2	0.3	0.45	2	0.27	50	4	9.8	2.8	3.1	3.4	3.6	4.1
ZSLNS20 03-2.5	0.3	0.45	2.5	0.27	50	4	9.4	3.4	3.7	4	4.3	4.7
ZSLNS20 03-3	0.3	0.45	3	0.27	50	4	9	3.9	4.3	4.6	4.9	5.4
ZSLNS20 04-1	0.4	0.6	1	0.37	50	4	10.7	1.7	1.9	2.2	2.4	2.7
ZSLNS20 04-1.5	0.4	0.6	1.5	0.37	50	4	10.2	2.3	2.5	2.8	3	3.4
ZSLNS20 04-2	0.4	0.6	2	0.37	50	4	9.7	2.8	3.1	3.4	3.6	4.1
ZSLNS20 04-2.5	0.4	0.6	2.5	0.37	50	4	9.3	3.4	3.7	4	4.3	4.7
ZSLNS20 04-3	0.4	0.6	3	0.37	50	4	8.9	3.9	4.3	4.6	4.9	5.4
ZSLNS20 04-3.5	0.4	0.6	3.5	0.37	50	4	8.6	4.5	4.9	5.2	5.5	6
ZSLNS20 04-4	0.4	0.6	4	0.37	50	4	8.2	5	5.4	5.8	6.1	6.6
ZSLNS20 04-5	0.4	0.6	5	0.37	50	4	7.6	6.1	6.6	6.9	7.3	7.8
ZSLNS20 04-6	0.4	0.6	6	0.37	50	4	7.1	7.2	7.7	8.1	8.4	9

▶ 적용 피삭재

○ : 적합 ◎ : 매우 적합

H		P			K	N			M	S
열처리강		탄소강	합금강	프리하트강	주철	동	흑연	알루미늄	스테인리스	내열합금
SKD61 ~HRc55	SKD11 HRc55~	~HB225	HB225 ~325	HRc30~50	~FCD500					
◎	◎		○	○						

Zamus Star
E-Star
U-Wing
Zamus Thunder
X-Star
S-Wing
A-Wing
Standard
Copper-Mate
Gra-Mate

ZSLNS20 2날 롱 넥 스퀘어 엔드밀

Endmill

Zamus Star

E-Star

U-Wing

Zamus Thunder

X-Star

S-Wing

A-Wing

Standard

Copper-Mate

Gra-Mate

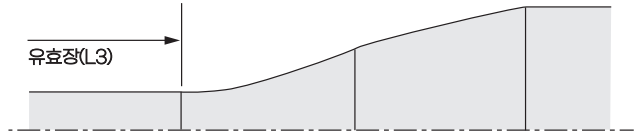
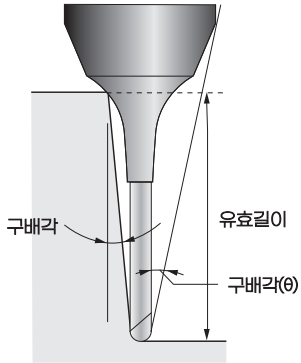

※ 표시된 유효길이는 공작물과의 간섭을 막기 위한 기본 값입니다.
가공환경의 적절한 제어가 필요합니다.

품목코드	DC	APMX	LU	DN	OAL	DCONMS	BHTA	가공물 구배각별 유효길이				
	날경	날장	유효장	유효경	전장	자루경	구배각	0.5°	1°	1.5°	2°	3°
ZSLNS20 05-1	0.5	0.75	1	0.47	50	4	10.7	1.7	1.9	2.2	2.4	2.7
ZSLNS20 05-1.5	0.5	0.75	1.5	0.47	50	4	10.2	2.3	2.5	2.8	3	3.4
ZSLNS20 05-2	0.5	0.75	2	0.47	50	4	9.7	2.8	3.1	3.4	3.6	4.1
ZSLNS20 05-2.5	0.5	0.75	2.5	0.47	50	4	9.3	3.4	3.7	4	4.3	4.7
ZSLNS20 05-3	0.5	0.75	3	0.47	50	4	8.9	3.9	4.3	4.6	4.9	5.4
ZSLNS20 05-4	0.5	0.75	4	0.47	50	4	8.1	5	5.4	5.8	6.1	6.6
ZSLNS20 05-5	0.5	0.75	5	0.47	50	4	7.5	6.1	6.6	6.9	7.3	7.8
ZSLNS20 05-6	0.5	0.75	6	0.47	50	4	7	7.2	7.7	8.1	8.4	9
ZSLNS20 05-8	0.5	0.75	8	0.47	50	4	6.2	9.3	9.9	10.3	10.7	11.4
ZSLNS20 06-2	0.6	0.9	2	0.57	50	4	9.6	2.8	3.1	3.4	3.6	4.1
ZSLNS20 06-4	0.6	0.9	4	0.57	50	4	8.1	5	5.4	5.8	6.1	6.6
ZSLNS20 06-6	0.6	0.9	6	0.57	50	4	6.9	7.2	7.7	8.1	8.4	9
ZSLNS20 06-8	0.6	0.9	8	0.57	50	4	6.1	9.3	9.9	10.3	10.7	11.4
ZSLNS20 06-10	0.6	0.9	10	0.57	50	4	5.4	11.5	12.1	12.6	13	13.7
ZSLNS20 07-2	0.7	1.05	2	0.67	50	4	9.6	2.8	3.1	3.4	3.6	4.1
ZSLNS20 07-4	0.7	1.05	4	0.67	50	4	8	5	5.4	5.8	6.1	6.6
ZSLNS20 07-6	0.7	1.05	6	0.67	50	4	6.9	7.2	7.7	8.1	8.4	9
ZSLNS20 07-8	0.7	1.05	8	0.67	50	4	6	9.3	9.9	10.3	10.7	11.4
ZSLNS20 07-10	0.7	1.05	10	0.67	50	4	5.3	11.5	12.1	12.6	13	13.7
ZSLNS20 08-4	0.8	1.2	4	0.77	50	4	7.9	5	5.4	5.8	6.1	6.6

▶ 적용 피삭재

○ : 적합 ◎ : 매우 적합

H		P			K	N			M	S
열처리강		탄소강	합금강	프리하든강	주철	동	흑연	알루미늄	스테인리스	내열합금
SKD61 ~HRc55	SKD11 HRc55~	~HB225	HB225 ~325	HRc30~50	~FCD500					
◎	◎		○	○						

ZSLNS20 2날 롱 넥 스퀘어 엔드밀

Endmill

품목코드	DC	APMX	LU	DN	OAL	DCONMS	BHTA	가공물 구배각별 유효길이				
	날경	날장	유효장	유효경	전장	자루경	구배각	0.5°	1°	1.5°	2°	3°
ZSLNS20 08-6	0.8	1.2	6	0.77	50	4	6.8	7.2	7.7	8.1	8.4	9
ZSLNS20 08-8	0.8	1.2	8	0.77	50	4	5.9	9.3	9.9	10.3	10.7	11.4
ZSLNS20 08-10	0.8	1.2	10	0.77	50	4	5.2	11.5	12.1	12.6	13	13.7
ZSLNS20 08-12	0.8	1.2	12	0.77	55	4	4.7	13.6	14.2	14.8	15.2	16
ZSLNS20 09-6	0.9	1.35	6	0.86	50	4	6.7	7.2	7.7	8.1	8.4	9.1
ZSLNS20 09-8	0.9	1.35	8	0.86	50	4	5.8	9.4	9.9	10.4	10.7	11.4
ZSLNS20 09-10	0.9	1.35	10	0.86	50	4	5.1	11.5	12.1	12.6	13	13.7
ZSLNS20 09-12	0.9	1.35	12	0.86	55	4	4.6	13.6	14.3	14.8	15.2	16
ZSLNS20 10-2	1	1.5	2	0.96	50	4	9.4	2.9	3.2	3.4	3.7	4.1
ZSLNS20 10-4	1	1.5	4	0.96	50	4	7.7	5.1	5.5	5.8	6.1	6.6
ZSLNS20 10-6	1	1.5	6	0.96	50	4	6.6	7.2	7.7	8.1	8.4	9.1
ZSLNS20 10-8	1	1.5	8	0.96	50	4	5.7	9.4	9.9	10.4	10.7	11.4
ZSLNS20 10-10	1	1.5	10	0.96	50	4	5	11.5	12.1	12.6	13	13.7
ZSLNS20 10-12	1	1.5	12	0.96	55	4	4.5	13.6	14.3	14.8	15.2	16
ZSLNS20 10-14	1	1.5	14	0.96	55	4	4.1	15.7	16.4	17	17.4	18.7
ZSLNS20 10-16	1	1.5	16	0.96	60	4	3.8	17.8	18.6	19.1	19.6	21.3
ZSLNS20 10-20	1	1.5	20	0.96	60	4	3.2	22	22.8	23.5	24	26.6
ZSLNS20 12-6	1.2	1.8	6	1.15	50	4	6.3	7.3	7.7	8.1	8.5	9.1
ZSLNS20 12-8	1.2	1.8	8	1.15	50	4	5.5	9.4	9.9	10.4	10.8	11.4
ZSLNS20 12-10	1.2	1.8	10	1.15	50	4	4.8	11.5	12.1	12.6	13	13.7
ZSLNS20 12-12	1.2	1.8	12	1.15	55	4	4.3	13.6	14.3	14.8	15.2	16
ZSLNS20 12-16	1.2	1.8	16	1.15	55	4	3.6	17.8	18.6	19.2	19.7	21.3
ZSLNS20 14-6	1.4	2.1	6	1.34	50	4	6.1	7.3	7.8	8.1	8.5	9.1
ZSLNS20 14-8	1.4	2.1	8	1.34	50	4	5.3	9.4	10	10.4	10.8	11.5
ZSLNS20 14-10	1.4	2.1	10	1.34	50	4	4.6	11.6	12.1	12.6	13	13.8
ZSLNS20 14-12	1.4	2.1	12	1.34	55	4	4.1	13.7	14.3	14.8	15.3	16.1
ZSLNS20 14-14	1.4	2.1	14	1.34	55	4	3.7	15.8	16.5	17	17.5	18.7
ZSLNS20 14-16	1.4	2.1	16	1.34	55	4	3.4	17.9	18.6	19.2	19.7	21.4
ZSLNS20 15-4	1.5	2.25	4	1.44	50	4	7.2	5.2	5.5	5.9	6.2	6.7
ZSLNS20 15-6	1.5	2.25	6	1.44	50	4	6	7.3	7.8	8.1	8.5	9.1
ZSLNS20 15-8	1.5	2.25	8	1.44	50	4	5.1	9.4	10	10.4	10.8	11.5
ZSLNS20 15-10	1.5	2.25	10	1.44	50	4	4.5	11.6	12.1	12.6	13	13.8
ZSLNS20 15-12	1.5	2.25	12	1.44	55	4	4	13.7	14.3	14.8	15.3	16.1
ZSLNS20 15-14	1.5	2.25	14	1.44	55	4	3.6	15.8	16.5	17	17.5	18.7

Zamus Star
E-Star
U-Wing
Zamus Thunder
X-Star
S-Wing
A-Wing
Standard
Copper-Mate
Gra-Mate

▶ 적용 피삭재

○ : 적합 ◎ : 매우 적합

H		P			K	N			M	S
열처리강		탄소강	합금강	프리하트강	주철	동	흑연	알루미늄	스테인리스	내열합금
SKD61 ~HRC55	SKD11 HRC55~	~HB225	HB225 ~325	HRC30~50	~FCD500					
◎	◎		○	○						

ZSLNS20 2날 롱 넥 스퀘어 엔드밀

Endmill

품목코드	DC	APMX	LU	DN	OAL	DCONMS	BHTA	가공물 구배각별 유효길이				
	날경	날장	유효장	유효경	전장	자루경	구배각	0.5°	1°	1.5°	2°	3°
ZSLNS20 15-16	1.5	2.25	16	1.44	55	4	3.3	17.9	18.6	19.2	19.7	-
ZSLNS20 15-18	1.5	2.25	18	1.44	60	4	3	20	20.7	21.3	21.9	-
ZSLNS20 15-20	1.5	2.25	20	1.44	60	4	2.8	22	22.9	23.5	24.1	-
ZSLNS20 15-25	1.5	2.25	25	1.44	65	4	2.4	27.3	28.1	28.8	30	-
ZSLNS20 16-6	1.6	2.4	6	1.54	50	4	5.9	7.3	7.8	8.1	8.5	9.1
ZSLNS20 16-8	1.6	2.4	8	1.54	50	4	5	9.4	10	10.4	10.8	11.5
ZSLNS20 16-10	1.6	2.4	10	1.54	50	4	4.4	11.6	12.1	12.6	13	13.8
ZSLNS20 16-12	1.6	2.4	12	1.54	55	4	3.9	13.7	14.3	14.8	15.3	16.1
ZSLNS20 16-14	1.6	2.4	14	1.54	55	4	3.5	15.8	16.5	17	17.5	18.7
ZSLNS20 16-16	1.6	2.4	16	1.54	55	4	3.2	17.9	18.6	19.2	19.7	21.4
ZSLNS20 16-18	1.6	2.4	18	1.54	60	4	2.9	20	20.7	21.3	21.9	-
ZSLNS20 16-20	1.6	2.4	20	1.54	60	4	2.7	22	22.9	23.5	24.1	-
ZSLNS20 18-6	1.8	2.7	6	1.73	50	4	5.6	7.4	7.8	8.2	8.5	9.1
ZSLNS20 18-8	1.8	2.7	8	1.73	50	4	4.8	9.5	10	10.4	10.8	11.5
ZSLNS20 18-10	1.8	2.7	10	1.73	50	4	4.2	11.6	12.2	12.6	13	13.8
ZSLNS20 18-12	1.8	2.7	12	1.73	55	4	3.7	13.7	14.3	14.8	15.3	16.1
ZSLNS20 18-14	1.8	2.7	14	1.73	55	4	3.3	15.8	16.5	17	17.5	18.8
ZSLNS20 18-16	1.8	2.7	16	1.73	55	4	3	17.9	18.6	19.2	19.7	-
ZSLNS20 18-18	1.8	2.7	18	1.73	60	4	2.7	20	20.7	21.3	21.9	-
ZSLNS20 18-20	1.8	2.7	20	1.73	60	4	2.5	22.1	22.9	23.5	24.1	-
ZSLNS20 20-4	2	3	4	1.92	50	4	6.5	5.3	5.6	5.9	6.2	6.7
ZSLNS20 20-6	2	3	6	1.92	50	4	5.3	7.4	7.8	8.2	8.5	9.1
ZSLNS20 20-8	2	3	8	1.92	50	4	4.5	9.5	10	10.4	10.8	11.5
ZSLNS20 20-10	2	3	10	1.92	50	4	3.9	11.6	12.2	12.7	13.1	13.8
ZSLNS20 20-12	2	3	12	1.92	55	4	3.4	13.7	14.3	14.9	15.3	16.1
ZSLNS20 20-14	2	3	14	1.92	55	4	3.1	15.8	16.5	17	17.5	18.8
ZSLNS20 20-16	2	3	16	1.92	55	4	2.8	17.9	18.6	19.2	19.7	-
ZSLNS20 20-18	2	3	18	1.92	60	4	2.6	20	20.8	21.4	21.9	-
ZSLNS20 20-20	2	3	20	1.92	60	4	2.4	22.1	22.9	23.5	24.1	-
ZSLNS20 20-25	2	3	25	1.92	65	4	2	27.3	28.2	28.9	-	-
ZSLNS20 20-30	2	3	30	1.92	70	4	1.7	32.5	33.4	34.4	-	-
ZSLNS20 25-8	2.5	3.75	8	2.4	50	4	3.7	9.6	10.1	10.5	10.9	11.5
ZSLNS20 25-10	2.5	3.75	10	2.4	50	4	3.1	11.7	12.2	12.7	13.1	13.8
ZSLNS20 25-12	2.5	3.75	12	2.4	55	4	2.7	13.8	14.4	14.9	15.3	-

▶ 적용 피삭재

○ : 적합 ◎ : 매우 적합

H		P			K	N			M	S
열처리강		탄소강	합금강	프리하든강	주철	동	흑연	알루미늄	스테인리스	내열합금
SKD61 ~HRc55	SKD11 HRc55~	~HB225	HB225 ~325	HRc30~50	~FCD500					
◎	◎		○	○						

ZSLNS20 2날 롱 넥 스퀘어 엔드밀

Endmill

품목코드	DC	APMX	LU	DN	OAL	DCONMS	BHTA	가공물 구배각별 유효길이				
	날경	날장	유효장	유효경	전장	자루경	구배각	0.5°	1°	1.5°	2°	3°
ZSLNS20 25-14	2.5	3.75	14	2.4	55	4	2.4	15.9	16.5	17.1	17.5	-
ZSLNS20 25-16	2.5	3.75	16	2.4	55	4	2.2	18	18.7	19.2	19.7	-
ZSLNS20 25-18	2.5	3.75	18	2.4	60	4	2	20.1	20.8	21.4	-	-
ZSLNS20 25-20	2.5	3.75	20	2.4	60	4	1.8	22.1	22.9	23.5	-	-
ZSLNS20 25-25	2.5	3.75	25	2.4	65	4	1.5	27.3	28.2	-	-	-
ZSLNS20 25-30	2.5	3.75	30	2.4	70	4	1.3	32.6	33.5	-	-	-
ZSLNS20 30-8	3	4.5	8	2.88	55	6	5.6	9.6	10.1	10.5	10.9	11.5
ZSLNS20 30-10	3	4.5	10	2.88	55	6	5	11.7	12.3	12.7	13.1	13.8
ZSLNS20 30-12	3	4.5	12	2.88	60	6	4.5	13.8	14.4	14.9	15.4	16.3
ZSLNS20 30-14	3	4.5	14	2.88	60	6	4.1	15.9	16.6	17.1	17.6	18.9
ZSLNS20 30-16	3	4.5	16	2.88	60	6	3.7	18	18.7	19.3	19.8	21.6
ZSLNS20 30-18	3	4.5	18	2.88	60	6	3.4	20.1	20.8	21.4	21.9	24.2
ZSLNS20 30-20	3	4.5	20	2.88	65	6	3.2	22.2	23	23.6	24.2	26.9
ZSLNS20 30-25	3	4.5	25	2.88	70	6	2.7	27.4	28.2	28.9	30.2	-
ZSLNS20 30-30	3	4.5	30	2.88	75	6	2.4	32.6	33.5	34.5	36.2	-
ZSLNS20 30-35	3	4.5	35	2.88	80	6	2.1	37.7	38.7	40.2	42.2	-
ZSLNS20 30-40	3	4.5	40	2.88	90	6	1.9	42.9	43.9	45.9	-	-
ZSLNS20 40-12	4	6	12	3.85	60	6	3.4	13.9	14.5	15	15.4	16.3
ZSLNS20 40-16	4	6	16	3.85	60	6	2.8	18.1	18.8	19.3	19.8	-
ZSLNS20 40-20	4	6	20	3.85	70	6	2.3	22.3	23	23.6	24.3	-
ZSLNS20 40-25	4	6	25	3.85	70	6	2	27.4	28.3	28.9	-	-
ZSLNS20 40-30	4	6	30	3.85	80	6	1.7	32.6	33.5	34.6	-	-
ZSLNS20 40-35	4	6	35	3.85	80	6	1.5	37.8	38.8	-	-	-
ZSLNS20 40-40	4	6	40	3.85	90	6	1.3	42.9	44	-	-	-
ZSLNS20 40-45	4	6	45	3.85	90	6	1.2	48.1	49.4	-	-	-
ZSLNS20 40-50	4	6	50	3.85	100	6	1.1	53.2	54.8	-	-	-
ZSLNS20 50-16	5	7.5	16	4.85	60	6	1.5	18.1	18.8	-	-	-
ZSLNS20 50-20	5	7.5	20	4.85	60	6	1.3	22.3	23	-	-	-
ZSLNS20 50-25	5	7.5	25	4.85	70	6	1.1	27.4	28.3	-	-	-
ZSLNS20 50-30	5	7.5	30	4.85	70	6	0.9	32.6	-	-	-	-
ZSLNS20 50-35	5	7.5	35	4.85	80	6	0.8	37.8	-	-	-	-
ZSLNS20 50-40	5	7.5	40	4.85	90	6	0.7	42.9	-	-	-	-
ZSLNS20 50-50	5	7.5	50	4.85	100	6	0.6	53.2	-	-	-	-

Zamus Star
E-Star
U-Wing
Zamus Thunder
X-Star
S-Wing
A-Wing
Standard
Copper-Mate
Gra-Mate

▶ 적용 피삭재

○ : 적합 ◎ : 매우 적합

H		P			K	N			M	S
열처리강		탄소강	합금강	프리하트강	주철	동	흑연	알루미늄	스테인리스	내열합금
SKD61 ~HRc55	SKD11 HRc55~	~HB225	HB225 ~325	HRc30~50	~FCD500					
◎	◎		○	○						

ZSLNS40 4날 롱 넥 스퀘어 엔드밀

Endmill

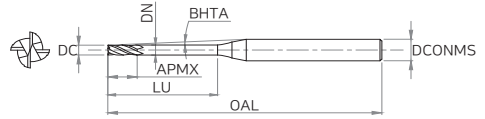

Zamus Star

E-Star

▶ 제품허용공차

날경(DC)		자루경
Ø1 ~ Ø5	0 ~ -0.015	h5

U-Wing

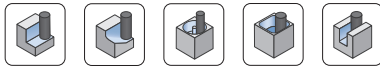

Zamus Thunder

X-Star

S-Wing

A-Wing

Standard

Copper-Mate

Gra-Mate

품목코드	DC	APMX	LU	DN	OAL	DCONMS	BHTA	가공물 구배각별 유효길이				
	날경	날장	유효장	유효경	전장	자루경	구배각	0.5°	1°	1.5°	2°	3°
ZSLNS40 10-4	1	1.5	4	0.96	50	4	7.7	5.1	5.5	5.8	6.1	6.6
ZSLNS40 10-6	1	1.5	6	0.96	50	4	6.6	7.2	7.7	8.1	8.4	9.1
ZSLNS40 10-8	1	1.5	8	0.96	50	4	5.7	9.4	9.9	10.4	10.7	11.4
ZSLNS40 10-10	1	1.5	10	0.96	50	4	5	11.5	12.1	12.6	13	13.7
ZSLNS40 15-4	1.5	2.25	4	1.44	50	4	7.2	5.2	5.5	5.9	6.2	6.7
ZSLNS40 15-6	1.5	2.25	6	1.44	50	4	6	7.3	7.8	8.1	8.5	9.1
ZSLNS40 15-8	1.5	2.25	8	1.44	50	4	5.1	9.4	10	10.4	10.8	11.5
ZSLNS40 15-10	1.5	2.25	10	1.44	50	4	4.5	11.6	12.1	12.6	13	13.8
ZSLNS40 15-12	1.5	2.25	12	1.44	55	4	4	13.7	14.3	14.8	15.3	16.1
ZSLNS40 15-14	1.5	2.25	14	1.44	55	4	3.6	15.8	16.5	17	17.5	18.7
ZSLNS40 15-16	1.5	2.25	16	1.44	55	4	3.3	17.9	18.6	19.2	19.7	-
ZSLNS40 15-18	1.5	2.25	18	1.44	60	4	3	20	20.7	21.3	21.9	-
ZSLNS40 15-20	1.5	2.25	20	1.44	60	4	2.8	22	22.9	23.5	24.1	-
ZSLNS40 15-25	1.5	2.25	25	1.44	65	4	2.4	27.3	28.1	28.8	30	-
ZSLNS40 20-4	2	3	4	1.92	50	4	6.5	5.3	5.6	5.9	6.2	6.7
ZSLNS40 20-6	2	3	6	1.92	50	4	5.3	7.4	7.8	8.2	8.5	9.1
ZSLNS40 20-8	2	3	8	1.92	50	4	4.5	9.5	10	10.4	10.8	11.5
ZSLNS40 20-10	2	3	10	1.92	50	4	3.9	11.6	12.2	12.7	13.1	13.8
ZSLNS40 20-12	2	3	12	1.92	55	4	3.4	13.7	14.3	14.9	15.3	16.1
ZSLNS40 20-14	2	3	14	1.92	55	4	3.1	15.8	16.5	17	17.5	18.8

▶ 적용 피삭재

○ : 적합 ◎ : 매우 적합

H		P			K	N			M	S
열처리강		탄소강	합금강	프리하든강	주철	동	흑연	알루미늄	스테인리스	내열합금
SKD61 ~HRc55	SKD11 HRc55~	~HB225	HB225 ~325	HRc30~50	~FCD500					
◎	◎		○	○						

ZSLNS40 4날 롱 넥 스퀘어 엔드밀

Endmill

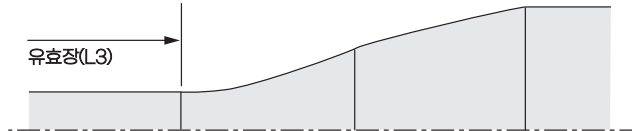
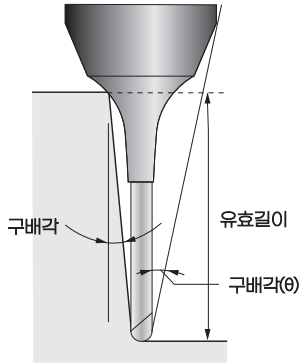

※ 표시된 유효길이는 공작물과의 간섭을 막기 위한 기본 값입니다.
가공환경의 적절한 제어가 필요합니다.

품목코드	DC	APMX	LU	DN	OAL	DCONMS	BHTA	가공용 구배각별 유효길이				
	날경	날장	유효장	유효경	전장	자루경	구배각	0.5°	1°	1.5°	2°	3°
ZSLNS40 20-16	2	3	16	1.92	55	4	2.8	17.9	18.6	19.2	19.7	-
ZSLNS40 20-18	2	3	18	1.92	60	4	2.6	20	20.8	21.4	21.9	-
ZSLNS40 20-20	2	3	20	1.92	60	4	2.4	22.1	22.9	23.5	24.1	-
ZSLNS40 20-25	2	3	25	1.92	65	4	2	27.3	28.2	28.9	-	-
ZSLNS40 20-30	2	3	30	1.92	70	4	1.7	32.5	33.4	34.4	-	-
ZSLNS40 25-8	2.5	3.75	8	2.4	50	4	3.7	9.6	10.1	10.5	10.9	11.5
ZSLNS40 25-10	2.5	3.75	10	2.4	50	4	3.1	11.7	12.2	12.7	13.1	13.8
ZSLNS40 25-12	2.5	3.75	12	2.4	55	4	2.7	13.8	14.4	14.9	15.3	-
ZSLNS40 25-14	2.5	3.75	14	2.4	55	4	2.4	15.9	16.5	17.1	17.5	-
ZSLNS40 25-16	2.5	3.75	16	2.4	55	4	2.2	18	18.7	19.2	19.7	-
ZSLNS40 25-18	2.5	3.75	18	2.4	60	4	2	20.1	20.8	21.4	-	-
ZSLNS40 25-20	2.5	3.75	20	2.4	60	4	1.8	22.1	22.9	23.5	-	-
ZSLNS40 25-25	2.5	3.75	25	2.4	65	4	1.5	27.3	28.2	-	-	-
ZSLNS40 25-30	2.5	3.75	30	2.4	70	4	1.3	32.6	33.5	-	-	-
ZSLNS40 30-8	3	4.5	8	2.88	55	6	5.6	9.6	10.1	10.5	10.9	11.5
ZSLNS40 30-10	3	4.5	10	2.88	55	6	5	11.7	12.3	12.7	13.1	13.8
ZSLNS40 30-12	3	4.5	12	2.88	60	6	4.5	13.8	14.4	14.9	15.4	16.3
ZSLNS40 30-14	3	4.5	14	2.88	60	6	4.1	15.9	16.6	17.1	17.6	18.9
ZSLNS40 30-16	3	4.5	16	2.88	60	6	3.7	18	18.7	19.3	19.8	21.6
ZSLNS40 30-18	3	4.5	18	2.88	60	6	3.4	20.1	20.8	21.4	21.9	24.2

▶ 적용 피삭재

○ : 적합 ◎ : 매우 적합

H		P			K	N			M	S
열처리강		탄소강	합금강	프리하트강	주철	동	흑연	알루미늄	스테인리스	내열합금
SKD61 ~HRc55	SKD11 HRc55~	~HB225	HB225 ~325	HRc30~50	~FCD500					
◎	◎		○	○						

ZSLNS40 4날 롱 넥 스퀘어 엔드밀

Endmill

품목코드	DC	APMX	LU	DN	OAL	DCONMS	BHTA	가공물 구배각별 유효길이				
	날경	날장	유효장	유효경	전장	자루경	구배각	0.5°	1°	1.5°	2°	3°
ZSLNS40 30-20	3	4.5	20	2.88	65	6	3.2	22.2	23	23.6	24.2	26.9
ZSLNS40 30-25	3	4.5	25	2.88	70	6	2.7	27.4	28.2	28.9	30.2	-
ZSLNS40 30-30	3	4.5	30	2.88	75	6	2.4	32.6	33.5	34.5	36.2	-
ZSLNS40 30-35	3	4.5	35	2.88	80	6	2.1	37.7	38.7	40.2	42.2	-
ZSLNS40 30-40	3	4.5	40	2.88	90	6	1.9	42.9	43.9	45.9	-	-
ZSLNS40 40-12	4	6	12	3.85	60	6	3.4	13.9	14.5	15	15.4	16.3
ZSLNS40 40-16	4	6	16	3.85	60	6	2.8	18.1	18.8	19.3	19.8	-
ZSLNS40 40-20	4	6	20	3.85	70	6	2.3	22.3	23	23.6	24.3	-
ZSLNS40 40-25	4	6	25	3.85	70	6	2	27.4	28.3	28.9	-	-
ZSLNS40 40-30	4	6	30	3.85	80	6	1.7	32.6	33.5	34.6	-	-
ZSLNS40 40-35	4	6	35	3.85	80	6	1.5	37.8	38.8	-	-	-
ZSLNS40 40-40	4	6	40	3.85	90	6	1.3	42.9	44	-	-	-
ZSLNS40 40-45	4	6	45	3.85	90	6	1.2	48.1	49.4	-	-	-
ZSLNS40 40-50	4	6	50	3.85	100	6	1.1	53.2	54.8	-	-	-
ZSLNS40 50-16	5	7.5	16	4.85	60	6	1.5	18.1	18.8	-	-	-
ZSLNS40 50-20	5	7.5	20	4.85	60	6	1.3	22.3	23	-	-	-
ZSLNS40 50-25	5	7.5	25	4.85	70	6	1.1	27.4	28.3	-	-	-
ZSLNS40 50-30	5	7.5	30	4.85	60	6	0.9	32.6	-	-	-	-
ZSLNS40 50-35	5	7.5	35	4.85	80	6	0.8	37.8	-	-	-	-
ZSLNS40 50-40	5	7.5	40	4.85	90	6	0.7	42.9	-	-	-	-
ZSLNS40 50-50	5	7.5	50	4.85	100	6	0.6	53.2	-	-	-	-

Zamus Star

E-Star

U-Wing

Zamus Thunder

X-Star

S-Wing

A-Wing

Standard

Copper -Mate

Gra -Mate

▶ 적용 피삭재

○ : 적합 ◎ : 매우 적합

H		P			K	N			M	S
열처리강		탄소강	합금강	프리하든강	주철	동	흑연	알루미늄	스테인리스	내열합금
SKD61 ~HRc55	SKD11 HRc55~	~HB225	HB225 ~325	HRc30~50	~FCD500					
◎	◎		○	○						

ZR702 2날 벅 래디우스 엔드밀

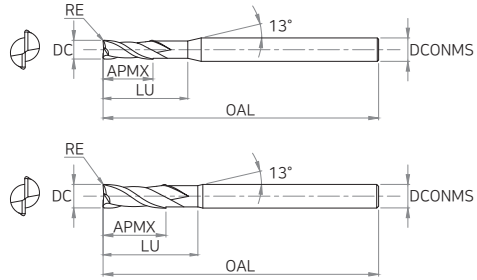

▶ 제품허용공차

날경(DC)		자루경
~ Ø6	0 ~ -0.012	
Ø8 ~ Ø12	0 ~ -0.015	h5

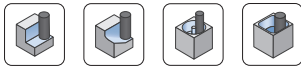

CARBIDE
AlTiN
2
30° HELIX
R ±0.01
R ±0.015
절삭조건 P.610

Ø6 이하 Ø6 초과

품목코드	DC	RE	APMX	LU	OAL	DCONMS
	날경	Corner R	날장	유효장	전장	자루경
ZR702 01000503S4	1	0.05	1.5	3	50	4
ZR702 01000504S4	1	0.05	1.5	4	50	4
ZR702 01000506S4	1	0.05	1.5	6	50	4
ZR702 01000508S4	1	0.05	1.5	8	50	4
ZR702 01000510S4	1	0.05	1.5	10	50	4
ZR702 0100103S4	1	0.1	1.5	3	50	4
ZR702 0100104S4	1	0.1	1.5	4	50	4
ZR702 0100106S4	1	0.1	1.5	6	50	4
ZR702 0100108S4	1	0.1	1.5	8	50	4
ZR702 0100110S4	1	0.1	1.5	10	50	4
ZR702 0100203S4	1	0.2	1.5	3	50	4
ZR702 0100204S4	1	0.2	1.5	4	50	4
ZR702 0100206S4	1	0.2	1.5	6	50	4
ZR702 0100208S4	1	0.2	1.5	8	50	4
ZR702 0100210S4	1	0.2	1.5	10	50	4
ZR702 0100303S4	1	0.3	1.5	3	50	4
ZR702 0100304S4	1	0.3	1.5	4	50	4
ZR702 0100306S4	1	0.3	1.5	6	50	4
ZR702 0100308S4	1	0.3	1.5	8	50	4
ZR702 0100310S4	1	0.3	1.5	10	50	4

▶ 적용 피삭재

○ : 적합 ◎ : 매우 적합

H		P			K	N			M	S
열처리강		탄소강	합금강	프리하든강	주철	동	흑연	알루미늄	스테인리스	내열합금
SKD61 ~HRc55	SKD11 HRc55~	~HB225	HB225 ~325	HRc30~50	~FCD500					
◎	◎		○	○						

ZR702 2날 벡 라디우스 엔드밀

Endmill

품목코드	DC	RE	APMX	LU	OAL	DCONMS
	날경	Corner R	날장	유효장	전장	자루경
ZR702 0100104	1	0.1	1.5	4	50	6
ZR702 0100106	1	0.1	1.5	6	50	6
ZR702 0100204	1	0.2	1.5	4	50	6
ZR702 0100206	1	0.2	1.5	6	50	6
ZR702 0100210	1	0.2	1.5	10	50	6
ZR702 0100212	1	0.2	1.5	12	50	6
ZR702 0120208	1.2	0.2	2	8	50	6
ZR702 0120212	1.2	0.2	2	12	50	6
ZR702 01500504S4	1.5	0.05	2.5	4	50	4
ZR702 01500506S4	1.5	0.05	2.5	6	50	4
ZR702 01500508S4	1.5	0.05	2.5	8	50	4
ZR702 01500510S4	1.5	0.05	2.5	10	50	4
ZR702 01500512S4	1.5	0.05	2.5	12	50	4
ZR702 0150104S4	1.5	0.1	2.5	4	50	4
ZR702 0150106S4	1.5	0.1	2.5	6	50	4
ZR702 0150108S4	1.5	0.1	2.5	8	50	4
ZR702 0150110S4	1.5	0.1	2.5	10	50	4
ZR702 0150112S4	1.5	0.1	2.5	12	50	4
ZR702 0150204S4	1.5	0.2	2.5	4	50	4
ZR702 0150206S4	1.5	0.2	2.5	6	50	4
ZR702 0150208S4	1.5	0.2	2.5	8	50	4
ZR702 0150210S4	1.5	0.2	2.5	10	50	4
ZR702 0150212S4	1.5	0.2	2.5	12	50	4
ZR702 0150304S4	1.5	0.3	2.5	4	50	4
ZR702 0150306S4	1.5	0.3	2.5	6	50	4
ZR702 0150308S4	1.5	0.3	2.5	8	50	4
ZR702 0150310S4	1.5	0.3	2.5	10	50	4
ZR702 0150312S4	1.5	0.3	2.5	12	50	4
ZR702 0150504S4	1.5	0.5	2.5	4	50	4
ZR702 0150506S4	1.5	0.5	2.5	6	50	4
ZR702 0150508S4	1.5	0.5	2.5	8	50	4
ZR702 0150510S4	1.5	0.5	2.5	10	50	4
ZR702 0150512S4	1.5	0.5	2.5	12	50	4
ZR702 0150204	1.5	0.2	2.5	4	50	6

▶ 적용 피삭재

○ : 적합 ◎ : 매우 적합

H		P			K	N			M	S
열처리강		탄소강	합금강	프리하든강	주철	동	흑연	알루미늄	스테인리스	내열합금
SKD61 ~HRc55	SKD11 HRc55~	~HB225	HB225 ~325	HRc30~50	~FCD500					
◎	◎		○	○						

ZR702 2날 벅 래디우스 엔드밀

Endmill

품목코드	DC	RE	APMX	LU	OAL	DCONMS
	날경	Corner R	날장	유효장	전장	자루경
ZR702 0150206	1.5	0.2	2.5	6	50	6
ZR702 0150208	1.5	0.2	2.5	8	50	6
ZR702 0150210	1.5	0.2	2.5	10	50	6
ZR702 0150215	1.5	0.2	2.5	15	50	6
ZR702 0200106S4	2	0.1	3	6	50	4
ZR702 0200108S4	2	0.1	3	8	50	4
ZR702 0200110S4	2	0.1	3	10	50	4
ZR702 0200112S4	2	0.1	3	12	50	4
ZR702 0200116S4	2	0.1	3	16	50	4
ZR702 0200120S4	2	0.1	3	20	50	4
ZR702 0200206S4	2	0.2	3	6	50	4
ZR702 0200208S4	2	0.2	3	8	50	4
ZR702 0200210S4	2	0.2	3	10	50	4
ZR702 0200212S4	2	0.2	3	12	50	4
ZR702 0200216S4	2	0.2	3	16	50	4
ZR702 0200220S4	2	0.2	3	20	50	4
ZR702 0200306S4	2	0.3	3	6	50	4
ZR702 0200308S4	2	0.3	3	8	50	4
ZR702 0200310S4	2	0.3	3	10	50	4
ZR702 0200312S4	2	0.3	3	12	50	4
ZR702 0200316S4	2	0.3	3	16	50	4
ZR702 0200320S4	2	0.3	3	20	50	4
ZR702 0200506S4	2	0.5	3	6	50	4
ZR702 0200508S4	2	0.5	3	8	50	4
ZR702 0200510S4	2	0.5	3	10	50	4
ZR702 0200512S4	2	0.5	3	12	50	4
ZR702 0200516S4	2	0.5	3	16	50	4
ZR702 0200520S4	2	0.5	3	20	50	4
ZR702 0200108	2	0.1	3	8	50	6
ZR702 0200112	2	0.1	3	12	50	6
ZR702 0200206	2	0.2	3	6	50	6
ZR702 0200209	2	0.2	3	9	50	6
ZR702 0200216	2	0.2	3	16	50	6
ZR702 0200306	2	0.3	3	6	50	6

Zamus Star
E-Star
U-Wing
Zamus Thunder
X-Star
S-Wing
A-Wing
Standard
Copper-Mate
Gra-Mate

▶ 적용 피삭재

○ : 적합 ◎ : 매우 적합

H		P			K	N			M	S
열처리강		탄소강	합금강	프리하든강	주철	동	흑연	알루미늄	스테인리스	내열합금
SKD61 ~HRc55	SKD11 HRc55~	~HB225	HB225 ~325	HRc30~50	~FCD500					
◎	◎		○	○						

ZR702 2날 벡 래디우스 엔드밀

Endmill

품목코드	DC	RE	APMX	LU	OAL	DCONMS
	날경	Corner R	날장	유효장	전장	자루경
ZR702 0200506	2	0.5	3	6	50	6
ZR702 0200509	2	0.5	3	9	50	6
ZR702 0200512	2	0.5	3	12	50	6
ZR702 0200516	2	0.5	3	16	50	6
ZR702 0250208S4	2.5	0.2	3.5	8	50	4
ZR702 0250210S4	2.5	0.2	3.5	10	50	4
ZR702 0250212S4	2.5	0.2	3.5	12	50	4
ZR702 0250216S4	2.5	0.2	3.5	16	50	4
ZR702 0250308S4	2.5	0.3	3.5	8	50	4
ZR702 0250310S4	2.5	0.3	3.5	10	50	4
ZR702 0250312S4	2.5	0.3	3.5	12	50	4
ZR702 0250316S4	2.5	0.3	3.5	16	50	4
ZR702 0250508S4	2.5	0.5	3.5	8	50	4
ZR702 0250510S4	2.5	0.5	3.5	10	50	4
ZR702 0250512S4	2.5	0.5	3.5	12	50	4
ZR702 0250516S4	2.5	0.5	3.5	16	50	4
ZR702 0300108	3	0.1	4.5	8	55	6
ZR702 0300110	3	0.1	4.5	10	55	6
ZR702 0300112	3	0.1	4.5	12	55	6
ZR702 0300116	3	0.1	4.5	16	55	6
ZR702 0300120	3	0.1	4.5	20	60	6
ZR702 0300208	3	0.2	4.5	8	55	6
ZR702 0300209	3	0.2	4.5	9	55	6
ZR702 0300210	3	0.2	4.5	10	55	6
ZR702 0300212	3	0.2	4.5	12	55	6
ZR702 0300216	3	0.2	4.5	16	55	6
ZR702 0300220	3	0.2	4.5	20	60	6
ZR702 0300308	3	0.3	4.5	8	55	6
ZR702 0300309	3	0.3	4.5	9	55	6
ZR702 0300310	3	0.3	4.5	10	55	6
ZR702 0300312	3	0.3	4.5	12	55	6
ZR702 0300314	3	0.3	4.5	14	55	6
ZR702 0300316	3	0.3	4.5	16	55	6
ZR702 0300320	3	0.3	4.5	20	60	6

▶ 적용 피삭재

○ : 적합 ◎ : 매우 적합

H		P			K	N			M	S
열처리강		탄소강	합금강	프리하든강	주철	동	흑연	알루미늄	스테인리스	내열합금
SKD61 ~HRc55	SKD11 HRc55~	~HB225	HB225 ~325	HRc30~50	~FCD500					
◎	◎		○	○						

ZR702 2날 벡 래디우스 엔드밀

Endmill

품목코드	DC	RE	APMX	LU	OAL	DCONMS
	날경	Corner R	날장	유효장	전장	자루경
ZR702 0300508	3	0.5	4.5	8	55	6
ZR702 0300509	3	0.5	4.5	9	55	6
ZR702 0300510	3	0.5	4.5	10	55	6
ZR702 0300512	3	0.5	4.5	12	55	6
ZR702 0300516	3	0.5	4.5	16	55	6
ZR702 0300520	3	0.5	4.5	20	60	6
ZR702 0301008	3	1	4.5	8	55	6
ZR702 0301010	3	1	4.5	10	55	6
ZR702 0301012	3	1	4.5	12	55	6
ZR702 0301016	3	1	4.5	16	55	6
ZR702 0301020	3	1	4.5	20	60	6
ZR702 0301025	3	1	4.5	25	60	6
ZR702 0400110	4	0.1	6	10	55	6
ZR702 0400112	4	0.1	6	12	55	6
ZR702 0400116	4	0.1	6	16	55	6
ZR702 0400120	4	0.1	6	20	60	6
ZR702 0400125	4	0.1	6	25	60	6
ZR702 0400210	4	0.2	6	10	55	6
ZR702 0400212	4	0.2	6	12	55	6
ZR702 0400216	4	0.2	6	16	55	6
ZR702 0400220	4	0.2	6	20	60	6
ZR702 0400225	4	0.2	6	25	60	6
ZR702 0400310	4	0.3	6	10	55	6
ZR702 0400312	4	0.3	6	12	55	6
ZR702 0400316	4	0.3	6	16	55	6
ZR702 0400320	4	0.3	6	20	60	6
ZR702 0400325	4	0.3	6	25	60	6
ZR702 0400510	4	0.5	6	10	55	6
ZR702 0400512	4	0.5	6	12	55	6
ZR702 0400516	4	0.5	6	16	55	6
ZR702 0400520	4	0.5	6	20	60	6
ZR702 0400525	4	0.5	6	25	60	6
ZR702 0400530	4	0.5	6	30	70	6
ZR702 0401010	4	1	6	10	55	6

Zamus Star
E-Star
U-Wing
Zamus Thunder
X-Star
S-Wing
A-Wing
Standard
Copper-Mate
Gra-Mate

▶ 적용 피삭재

○ : 적합 ◎ : 매우 적합

H		P			K	N			M	S
열처리강		탄소강	합금강	프리하든강	주철	동	흑연	알루미늄	스테인리스	내열합금
SKD61 ~HRc55	SKD11 HRc55~	~HB225	HB225 ~325	HRc30~50	~FCD500					
◎	◎		○	○						

ZR702 2날 벡 래디우스 엔드밀

Endmill

Zamus Star

E-Star

U-Wing

Zamus Thunder

X-Star

S-Wing

A-Wing

Standard

Copper -Mate

Gra -Mate

품목코드	DC	RE	APMX	LU	OAL	DCONMS
	날경	Corner R	날장	유효장	전장	자루경
ZR702 0401012	4	1	6	12	55	6
ZR702 0401016	4	1	6	16	55	6
ZR702 0401020	4	1	6	20	60	6
ZR702 0401025	4	1	6	25	60	6
ZR702 0401030	4	1	6	30	70	6
ZR702 0500318	5	0.3	8	18	60	6
ZR702 0600220	6	0.2	9	20	60	6
ZR702 0600320	6	0.3	9	20	60	6
ZR702 0600520	6	0.5	9	20	60	6
ZR702 0601020	6	1	9	20	60	6
ZR702 0601520	6	1.5	9	20	60	6
ZR702 0602020	6	2	9	20	60	6
ZR702 0800225	8	0.2	12	25	60	8
ZR702 0800325	8	0.3	12	25	60	8
ZR702 0800525	8	0.5	12	25	60	8
ZR702 0801025	8	1	12	25	60	8
ZR702 0801525	8	1.5	12	25	60	8
ZR702 1000232	10	0.2	15	32	70	10
ZR702 1000332	10	0.3	15	32	70	10
ZR702 1000532	10	0.5	15	32	70	10
ZR702 1001032	10	1	15	32	70	10
ZR702 1001532	10	1.5	15	32	70	10
ZR702 1002032	10	2	15	32	70	10
ZR702 1200338	12	0.3	18	38	80	12
ZR702 1200538	12	0.5	18	38	80	12
ZR702 1201038	12	1	18	38	80	12
ZR702 1201538	12	1.5	18	38	80	12
ZR702 1202038	12	2	18	38	80	12

▶ 적용 피삭재

○ : 적합 ◎ : 매우 적합

H		P			K	N			M	S
열처리강		탄소강	합금강	프리하든강	주철	동	흑연	알루미늄	스테인리스	내열합금
SKD61 ~HRc55	SKD11 HRc55~	~HB225	HB225 ~325	HRc30~50	~FCD500					
◎	◎		○	○						

ZR704 4날 넥 래디우스 엔드밀

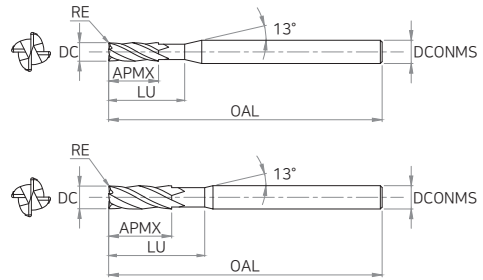

▶ 제품허용공차

날경(DC)		자루경
~ Ø6	0 ~ -0.012	
Ø8 ~ Ø12	0 ~ -0.015	

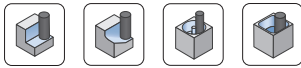

품목코드	DC	RE	APMX	LU	OAL	DCONMS
	날경	Corner R	날장	유효장	전장	자루경
ZR704 0100103S4	1	0.1	2	3	50	4
ZR704 0100104S4	1	0.1	2	4	50	4
ZR704 0100106S4	1	0.1	2	6	50	4
ZR704 0100203S4	1	0.2	2	3	50	4
ZR704 0100204S4	1	0.2	2	4	50	4
ZR704 0100206S4	1	0.2	2	6	50	4
ZR704 0100303S4	1	0.3	2	3	50	4
ZR704 0100304S4	1	0.3	2	4	50	4
ZR704 0100306S4	1	0.3	2	6	50	4
ZR704 0150104S4	1.5	0.1	2.5	4	50	4
ZR704 0150106S4	1.5	0.1	2.5	6	50	4
ZR704 0150204S4	1.5	0.2	2.5	4	50	4
ZR704 0150206S4	1.5	0.2	2.5	6	50	4
ZR704 0150304S4	1.5	0.3	2.5	4	50	4
ZR704 0150306S4	1.5	0.3	2.5	6	50	4
ZR704 0200106S4	2	0.1	3	6	50	4
ZR704 0200108S4	2	0.1	3	8	50	4
ZR704 0200206S4	2	0.2	3	6	50	4
ZR704 0200208S4	2	0.2	3	8	50	4
ZR704 0200306S4	2	0.3	3	6	50	4

▶ 적용 피삭재

○ : 적합 ◎ : 매우 적합

H		P			K	N			M	S
열처리강		탄소강	합금강	프리하든강	주철	동	흑연	알루미늄	스테인리스	내열합금
SKD61 ~HRc55	SKD11 HRc55~	~HB225	HB225 ~325	HRc30~50	~FCD500					
◎	◎		○	○						

ZR704 4날 벡 래디우스 엔드밀

Endmill

품목코드	DC	RE	APMX	LU	OAL	DCONMS
	날경	Corner R	날장	유효장	전장	자루경
ZR704 0200308S4	2	0.3	3	8	50	4
ZR704 0200506S4	2	0.5	3	6	50	4
ZR704 0200508S4	2	0.5	3	8	50	4
ZR704 0200208	2	0.2	3	8	50	6
ZR704 0200210	2	0.2	3	10	50	6
ZR704 0200212	2	0.2	3	12	50	6
ZR704 0250106S4	2.5	0.1	3.5	6	50	4
ZR704 0300108	3	0.1	4	8	55	6
ZR704 0300110	3	0.1	4	10	55	6
ZR704 0300112	3	0.1	4	12	55	6
ZR704 0300116	3	0.1	4	16	55	6
ZR704 0300120	3	0.1	4	20	60	6
ZR704 0300208	3	0.2	4	8	55	6
ZR704 0300210	3	0.2	4	10	55	6
ZR704 0300212	3	0.2	4	12	55	6
ZR704 0300216	3	0.2	4	16	55	6
ZR704 0300220	3	0.2	4	20	60	6
ZR704 0300308	3	0.3	4	8	55	6
ZR704 0300309	3	0.3	4	9	55	6
ZR704 0300310	3	0.3	4	10	55	6
ZR704 0300312	3	0.3	4	12	55	6
ZR704 0300316	3	0.3	4	16	55	6
ZR704 0300320	3	0.3	4	20	60	6
ZR704 0300508	3	0.5	4	8	55	6
ZR704 0300509	3	0.5	4	9	55	6
ZR704 0300510	3	0.5	4	10	55	6
ZR704 0300512	3	0.5	4	12	55	6
ZR704 0300516	3	0.5	4	16	55	6
ZR704 0300520	3	0.5	4	20	60	6
ZR704 0301008	3	1	4	8	55	6
ZR704 0301010	3	1	4	10	55	6
ZR704 0301012	3	1	4	12	55	6
ZR704 0301016	3	1	4	16	55	6
ZR704 0301020	3	1	4	20	60	6

▶ 적용 피삭재

○ : 적합 ◎ : 매우 적합

H		P			K	N			M	S
열처리강		탄소강	합금강	프리하든강	주철	동	흑연	알루미늄	스테인리스	내열합금
SKD61 ~HRc55	SKD11 HRc55~	~HB225	HB225 ~325	HRc30~50	~FCD500					
◎	◎		○	○						

ZR704 4날 벡 래디우스 엔드밀

Endmill

품목코드	DC	RE	APMX	LU	OAL	DCONMS
	날경	Corner R	날장	유효장	전장	자루경
ZR704 0400110	4	0.1	6	10	55	6
ZR704 0400112	4	0.1	6	12	55	6
ZR704 0400116	4	0.1	6	16	55	6
ZR704 0400120	4	0.1	6	20	60	6
ZR704 0400125	4	0.1	6	25	60	6
ZR704 0400210	4	0.2	6	10	55	6
ZR704 0400212	4	0.2	6	12	55	6
ZR704 0400216	4	0.2	6	16	55	6
ZR704 0400220	4	0.2	6	20	60	6
ZR704 0400225	4	0.2	6	25	60	6
ZR704 0400310	4	0.3	6	10	55	6
ZR704 0400312	4	0.3	6	12	55	6
ZR704 0400316	4	0.3	6	16	55	6
ZR704 0400320	4	0.3	6	20	60	6
ZR704 0400325	4	0.3	6	25	55	6
ZR704 0400510	4	0.5	6	10	55	6
ZR704 0400512	4	0.5	6	12	55	6
ZR704 0400516	4	0.5	6	16	55	6
ZR704 0400520	4	0.5	6	20	60	6
ZR704 0400525	4	0.5	6	25	60	6
ZR704 0401010	4	1	6	10	55	6
ZR704 0401012	4	1	6	12	55	6
ZR704 0401016	4	1	6	16	55	6
ZR704 0401020	4	1	6	20	60	6
ZR704 0401025	4	1	6	25	60	6
ZR704 0600220	6	0.2	9	20	60	6
ZR704 0600320	6	0.3	9	20	60	6
ZR704 0600520	6	0.5	9	20	60	6
ZR704 0601020	6	1	9	20	60	6
ZR704 0601520	6	1.5	9	20	60	6
ZR704 0602020	6	2	9	20	60	6
ZR704 0800225	8	0.2	12	25	60	8
ZR704 0800325	8	0.3	12	25	60	8
ZR704 0800525	8	0.5	12	25	60	8

Zamus Star
E-Star
U-Wing
Zamus Thunder
X-Star
S-Wing
A-Wing
Standard
Copper-Mate
Gra-Mate

▶ 적용 피삭재

○ : 적합 ◎ : 매우 적합

H		P			K	N			M	S
열처리강		탄소강	합금강	프리하든강	주철	동	흑연	알루미늄	스테인리스	내열합금
SKD61 ~HRc55	SKD11 HRc55~	~HB225	HB225 ~325	HRc30~50	~FCD500					
◎	◎		○	○						

ZR704 4날 벡 래디우스 엔드밀

Endmill

Zamus Star

E-Star

U-Wing

Zamus Thunder

X-Star

S-Wing

A-Wing

Standard

Copper -Mate

Gra -Mate

품목코드	DC	RE	APMX	LU	OAL	DCONMS
	날경	Corner R	날장	유효장	전장	자루경
ZR704 0801025	8	1	12	25	60	8
ZR704 0801525	8	1.5	12	25	60	8
ZR704 0802025	8	2	12	25	60	8
ZR704 1000232	10	0.2	15	32	70	10
ZR704 1000332	10	0.3	15	32	70	10
ZR704 1000532	10	0.5	15	32	70	10
ZR704 1001032	10	1	15	32	70	10
ZR704 1001532	10	1.5	15	32	70	10
ZR704 1002032	10	2	15	32	70	10
ZR704 1200338	12	0.3	18	38	80	12
ZR704 1200538	12	0.5	18	38	80	12
ZR704 1201038	12	1	18	38	80	12
ZR704 1201538	12	1.5	18	38	80	12
ZR704 1202038	12	2	18	38	80	12

▶ 적용 피삭재

○ : 적합 ◎ : 매우 적합

H		P			K	N			M	S
열처리강		탄소강	합금강	프리하든강	주철	동	흑연	알루미늄	스테인리스	내열합금
SKD61 ~HRc55	SKD11 HRc55~	~HB225	HB225 ~325	HRc30~50	~FCD500					
◎	◎		○	○						

ZR706 6날 벡 라디우스 엔드밀

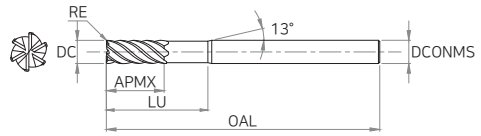

▶ 제품허용공차

날경(DC)		자루경
전 규격	0 ~ -0.02	h5

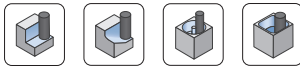

CARBIDE
AlTiN
6
45° HELIX
R ±0.01 (Ø6 이하)
R ±0.015 (Ø6 초과)
절삭조건 P.608

품목코드	DC	RE	APMX	LU	OAL	DCONMS
	날경	Corner R	날장	유효장	전장	자루경
ZR706 0600314	6	0.3	6	14	50	6
ZR706 0600514	6	0.5	6	14	50	6
ZR706 0800524	8	0.5	8	24	60	8
ZR706 0801024	8	1	8	24	60	8
ZR706 1000530	10	0.5	10	30	70	10
ZR706 1001030	10	1	10	30	70	10
ZR706 1200530	12	0.5	12	30	75	12
ZR706 1201030	12	1	12	30	75	12

▶ 적용 피삭재

○ : 적합 ◎ : 매우 적합

H		P			K	N			M	S
열처리강		탄소강	합금강	프리하든강	주철	동	흑연	알루미늄	스테인리스	내열합금
SKD61 ~HRC55	SKD11 HRC55~	~HB225	HB225 ~325	HRC30~50	~FCD500					
◎	◎		○	○						

ZR714 4날 라디우스 엔드밀

Endmill

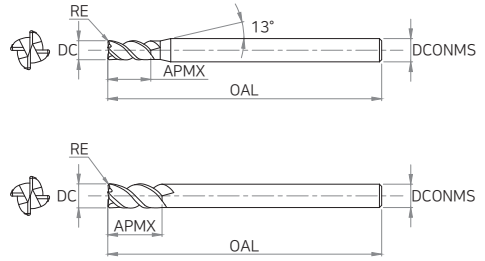

Zamus Star

▶ 제품허용공차

날경(DC)		자루경
~ Ø6	0 ~ -0.012	h5
Ø8 ~ Ø12	0 ~ -0.015	

U-Wing

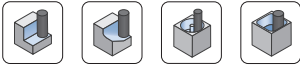

Zamus Thunder

품목코드	DC	RE	APMX	OAL	DCONMS	품목코드	DC	RE	APMX	OAL	DCONMS
	날경	Corner R	날장	전장	자루경		날경	Corner R	날장	전장	자루경
ZR714 0303	3	0.3	8	50	6	ZR714 1005	10	0.5	25	70	10
ZR714 0305	3	0.5	8	50	6	ZR714 1010	10	1	25	70	10
ZR714 0403	4	0.3	11	50	6	ZR714 1015	10	1.5	25	70	10
ZR714 0405	4	0.5	11	50	6	ZR714 1020	10	2	25	70	10
ZR714 0410	4	1	11	50	6	ZR714 1025	10	2.5	25	70	10
ZR714 0603	6	0.3	15	60	6	ZR714 1030	10	3	25	70	10
ZR714 0605	6	0.5	15	60	6	ZR714 1203	12	0.3	30	80	12
ZR714 0610	6	1	15	60	6	ZR714 1205	12	0.5	30	80	12
ZR714 0803	8	0.3	20	60	8	ZR714 1210	12	1	30	80	12
ZR714 0805	8	0.5	20	60	8	ZR714 1215	12	1.5	30	80	12
ZR714 0810	8	1	20	60	8	ZR714 1220	12	2	30	80	12
ZR714 0815	8	1.5	20	60	8	ZR714 1225	12	2.5	30	80	12
ZR714 0820	8	2	20	60	8	ZR714 1230	12	3	30	80	12
ZR714 1003	10	0.3	25	70	10						

Copper -Mate

Gra -Mate

▶ 적용 피삭재

○ : 적합 ◎ : 매우 적합

H		P			K	N			M	S
열처리강		탄소강	합금강	프리하든강	주철	동	흑연	알루미늄	스테인리스	내열합금
SKD61 ~HRc55	SKD11 HRc55~	~HB225	HB225 ~325	HRc30~50	~FCD500					
◎	◎		○	○						

ZR724 4날 벅 래디우스 엔드밀

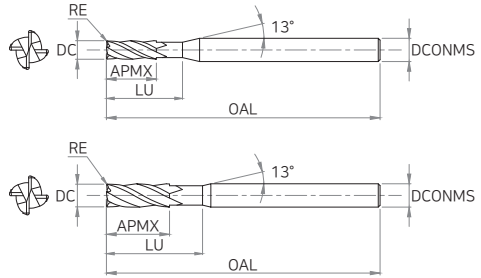

▶ 제품허용공차

날경(DC)		자루경
~ Ø6	0 ~ -0.012	
Ø8 ~ Ø12	0 ~ -0.015	h5

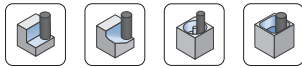

CARBIDE
AlTiN
4
30° HELIX
R ±0.01
R ±0.015
절삭조건 P.611

품목코드	DC	RE	APMX	LU	OAL	DCONMS
	날경	Corner R	날장	유효장	전장	자루경
ZR724 0600520	6	0.5	9	20	90	6
ZR724 0601020	6	1	9	20	90	6
ZR724 0800525	8	0.5	12	25	100	8
ZR724 0801025	8	1	12	25	100	8
ZR724 1000532	10	0.5	15	32	100	10
ZR724 1001032	10	1	15	32	100	10
ZR724 1002032	10	2	15	32	100	10
ZR724 1200538	12	0.5	18	38	110	12
ZR724 1201038	12	1	18	38	110	12
ZR724 1202038	12	2	18	38	110	12

▶ 적용 피삭재

○ : 적합 ◎ : 매우 적합

H		P			K	N			M	S
열처리강		탄소강	합금강	프리하든강	주철	동	흑연	알루미늄	스테인리스	내열합금
SKD61 ~Hrc55	SKD11 Hrc55~	~HB225	HB225 ~325	Hrc30~50	~FCD500					
◎	◎		○	○						

ZR732

2날 롱 생크 라디우스 엔드밀

Endmill

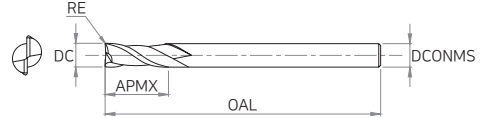
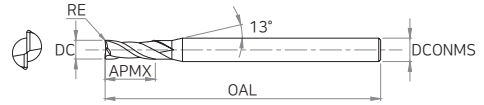

▶ 제품허용공차

날경(DC)		자루경
~ Ø6	0 ~ -0.012	h5
Ø8 ~ Ø12	0 ~ -0.015	

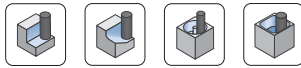

품목코드	DC	RE	APMX	OAL	DCONMS
	날경	Corner R	날장	전장	자루경
ZR732 01001	1	0.1	2	50	6
ZR732 01002	1	0.2	2	50	6
ZR732 01003	1	0.3	2	50	6
ZR732 01501	1.5	0.1	3	50	6
ZR732 01502	1.5	0.2	3	50	6
ZR732 01503	1.5	0.3	3	50	6
ZR732 01505	1.5	0.5	3	50	6
ZR732 02001	2	0.1	5	50	6
ZR732 02002	2	0.2	5	50	6
ZR732 02003	2	0.3	5	50	6
ZR732 02005	2	0.5	5	50	6
ZR732 02501	2.5	0.1	7	60	6
ZR732 02502	2.5	0.2	7	60	6
ZR732 02503	2.5	0.3	7	60	6
ZR732 02505	2.5	0.5	7	60	6
ZR732 03001	3	0.1	8	60	6
ZR732 03002	3	0.2	8	60	6
ZR732 03003	3	0.3	8	60	6
ZR732 03005	3	0.5	8	60	6
ZR732 04001	4	0.1	10	70	6

▶ 적용 피삭재

○ : 적합 ◎ : 매우 적합

H		P			K	N			M	S
열처리강		탄소강	합금강	프리하든강	주철	동	흑연	알루미늄	스테인리스	내열합금
SKD61 ~HRc55	SKD11 HRc55~	~HB225	HB225 ~325	HRc30~50	~FCD500					
◎	◎		○	○						

ZR732

2날 롱 생크 래디우스 엔드밀

Endmill

품목코드	DC	RE	APMX	OAL	DCONMS
	날경	Corner R	날장	전장	자루경
ZR732 04002	4	0.2	10	70	6
ZR732 04003	4	0.3	10	70	6
ZR732 04005	4	0.5	10	70	6
ZR732 04010	4	1	10	70	6
ZR732 05001	5	0.1	13	80	6
ZR732 05002	5	0.2	13	80	6
ZR732 05003	5	0.3	13	80	6
ZR732 05005	5	0.5	13	80	6
ZR732 05010	5	1	13	80	6
ZR732 06001	6	0.1	15	90	6
ZR732 06002	6	0.2	15	90	6
ZR732 06003	6	0.3	15	90	6
ZR732 06005	6	0.5	15	90	6
ZR732 06010	6	1	15	90	6
ZR732 08001	8	0.1	20	100	8
ZR732 08002	8	0.2	20	100	8
ZR732 08003	8	0.3	20	100	8
ZR732 08005	8	0.5	20	100	8
ZR732 08010	8	1	20	100	8
ZR732 08020	8	2	20	100	8
ZR732 10002	10	0.2	25	100	10
ZR732 10003	10	0.3	25	100	10
ZR732 10005	10	0.5	25	100	10
ZR732 10010	10	1	25	100	10
ZR732 10020	10	2	25	100	10
ZR732 12002	12	0.2	30	110	12
ZR732 12003	12	0.3	30	110	12
ZR732 12005	12	0.5	30	110	12
ZR732 12010	12	1	30	110	12
ZR732 12020	12	2	30	110	12

Zamus Star

E-Star

U-Wing

Zamus Thunder

X-Star

S-Wing

A-Wing

Standard

Copper-Mate

Gra-Mate

▶ 적용 피삭재

○ : 적합 ◎ : 매우 적합

H		P			K	N			M	S
열처리강		탄소강	합금강	프리하트강	주철	동	흑연	알루미늄	스테인리스	내열합금
SKD61 ~HRc55	SKD11 HRc55~	~HB225	HB225 ~325	HRc30~50	~FCD500					
◎	◎		○	○						

ZR734 4날 롱 생크 래디우스 엔드밀

Endmill

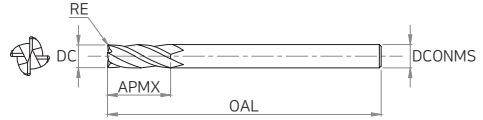
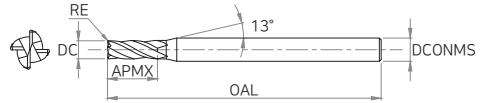

▶ 제품허용공차

날경(DC)		자루경
~ Ø6	0 ~ -0.012	h5
Ø8 ~ Ø12	0 ~ -0.015	

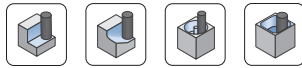

품목코드	DC	RE	APMX	OAL	DCONMS
	날경	Corner R	날장	전장	자루경
ZR734 01001	1	0.1	2	50	6
ZR734 01002	1	0.2	2	50	6
ZR734 01003	1	0.3	2	50	6
ZR734 01501	1.5	0.1	3	50	6
ZR734 01502	1.5	0.2	3	50	6
ZR734 01503	1.5	0.3	3	50	6
ZR734 01505	1.5	0.5	3	50	6
ZR734 02001	2	0.1	5	50	6
ZR734 02002	2	0.2	5	50	6
ZR734 02003	2	0.3	5	50	6
ZR734 02005	2	0.5	5	50	6
ZR734 02501	2.5	0.1	7	60	6
ZR734 02502	2.5	0.2	7	60	6
ZR734 02503	2.5	0.3	7	60	6
ZR734 02505	2.5	0.5	7	60	6
ZR734 03001	3	0.1	8	60	6
ZR734 03002	3	0.2	8	60	6
ZR734 03003	3	0.3	8	60	6
ZR734 03005	3	0.5	8	60	6
ZR734 04001	4	0.1	10	70	6

품목코드	DC	RE	APMX	OAL	DCONMS
	날경	Corner R	날장	전장	자루경
ZR734 04002	4	0.2	10	70	6
ZR734 04003	4	0.3	10	70	6
ZR734 04005	4	0.5	10	70	6
ZR734 04010	4	1	10	70	6
ZR734 05001	5	0.1	13	80	6
ZR734 05002	5	0.2	13	80	6
ZR734 05003	5	0.3	13	80	6
ZR734 05005	5	0.5	13	80	6
ZR734 05010	5	1	13	80	6
ZR734 06001	6	0.1	15	90	6
ZR734 06002	6	0.2	15	90	6
ZR734 06003	6	0.3	15	90	6
ZR734 06005	6	0.5	15	90	6
ZR734 06010	6	1	15	90	6
ZR734 08001	8	0.1	20	100	8
ZR734 08002	8	0.2	20	100	8
ZR734 08003	8	0.3	20	100	8
ZR734 08005	8	0.5	20	100	8
ZR734 08010	8	1	20	100	8
ZR734 08020	8	2	20	100	8

▶ 적용 피삭재

○ : 적함 ◎ : 매우 적함

H		P			K	N			M	S
열처리강		탄소강	합금강	프리하든강	주철	동	흑연	알루미늄	스테인리스	내열합금
SKD61 ~HRc55	SKD11 HRc55~	~HB225	HB225 ~325	HRc30~50	~FCD500					
◎	◎		○	○						

ZR734 4날 롱 생크 래디우스 엔드밀

Endmill

품목코드	DC	RE	APMX	OAL	DCONMS
	날경	Corner R	날장	전장	자루경
ZR734 10002	10	0.2	25	100	10
ZR734 10003	10	0.3	25	100	10
ZR734 10005	10	0.5	25	100	10
ZR734 10010	10	1	25	100	10
ZR734 10020	10	2	25	100	10

품목코드	DC	RE	APMX	OAL	DCONMS
	날경	Corner R	날장	전장	자루경
ZR734 12002	12	0.2	30	110	12
ZR734 12003	12	0.3	30	110	12
ZR734 12005	12	0.5	30	110	12
ZR734 12010	12	1	30	110	12
ZR734 12020	12	2	30	110	12

Zamus Star

E-Star

U-Wing

Zamus Thunder

X-Star

S-Wing

A-Wing

Standard

Copper-Mate

Gra-Mate

▶ 적용 피삭재

○ : 적합 ◎ : 매우 적합

H		P			K	N			M	S
열처리강		탄소강	합금강	프리하든강	주철	동	흑연	알루미늄	스테인리스	내열합금
SKD61 ~HRc55	SKD11 HRc55~	~HB225	HB225 ~325	HRc30~50	~FCD500					
◎	◎		○	○						

ZR736 6날 래디우스 엔드밀

Endmill

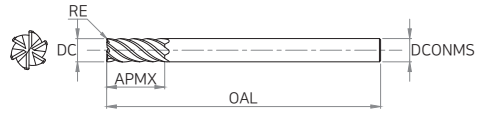

Zamus Star

E-Star

▶ 제품허용공차

날경(DC)		자루경
전 규격	0 ~ -0.02	h5

U-Wing

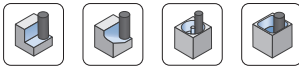

Ø6 이하

Ø6 초과

Zamus Thunder

품목코드	DC	RE	APMX	OAL	DCONMS
	날경	Corner R	날장	전장	자루경
ZR736 06005	6	0.5	15	90	6
ZR736 06010	6	1	15	90	6
ZR736 08005	8	0.5	20	100	8
ZR736 08010	8	1	20	100	8
ZR736 10005	10	0.5	25	100	10
ZR736 10010	10	1	25	100	10
ZR736 12005	12	0.5	30	110	12
ZR736 12010	12	1	30	110	12

A-Wing

Standard

Copper -Mate

Gra -Mate

▶ 적용 피삭재

○ : 적합 ◎ : 매우 적합

H		P			K	N			M	S
열처리강		탄소강	합금강	프리하든강	주철	동	흑연	알루미늄	스테인리스	내열합금
SKD61 ~HRc55	SKD11 HRc55~	~HB225	HB225 ~325	HRc30~50	~FCD500					
◎	◎		○	○						

ZS1(2)04 4날 벡 라디우스 엔드밀

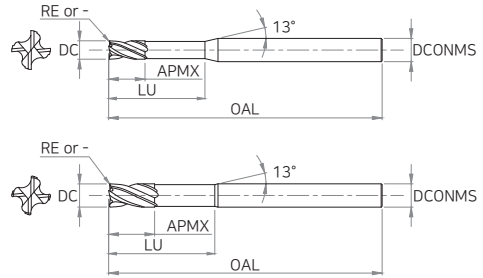

▶ 제품허용공차

날경(DC)		자루경
전 규격	0 ~ -0.02	h5

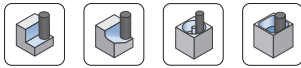

품목코드	DC	RE	APMX	LU	OAL	DCONMS
	날경	Corner R	날장	유효장	전장	자루경
ZS104 010	1	-	1.5	4	45	4
ZS204 010	1	0.05	1.5	4	45	4
ZS104 020	2	-	3	6	45	4
ZS204 020	2	0.05	3	6	45	4
ZS104 030	3	-	4	7	45	6
ZS204 030	3	0.1	4	7	45	6
ZS104 040	4	-	5	9	45	6
ZS204 040	4	0.1	5	9	45	6
ZS104 060	6	-	7	14	50	6
ZS204 060	6	0.2	7	14	50	6
ZS104 080	8	-	9	18	60	8
ZS204 080	8	0.2	9	18	60	8
ZS104 100	10	-	12	25	75	10
ZS204 100	10	0.2	12	25	75	10
ZS104 120	12	-	15	30	75	12
ZS204 120	12	0.3	15	30	75	12

▶ 적용 피삭재

○ : 적합 ◎ : 매우 적합

H		P			K	N			M	S
열처리강		탄소강	합금강	프리하트강	주철	동	흑연	알루미늄	스테인리스	내열합금
SKD61 ~HRC55	SKD11 HRC55~	~HB225	HB225 ~325	HRC30~50	~FCD500					
◎	◎		○	○						

ZS204 4날 넥 래디우스 엔드밀

Endmill

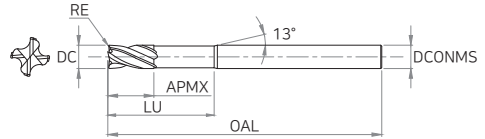
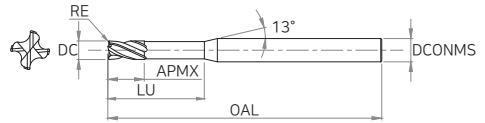

▶ 제품허용공차

날경(DC)		자루경
전 규격	0 ~ -0.02	h5

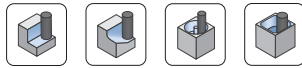

품목코드	DC	RE	APMX	LU	OAL	DCONMS
	날경	Corner R	날장	유효장	전장	자루경
ZS204 02000507	2	0.05	2.5	7	50	4
ZS204 0200107	2	0.1	2.5	7	50	4
ZS204 0300109	3	0.1	4	9	55	6
ZS204 0300209	3	0.2	4	9	55	6
ZS204 0300309	3	0.3	4	9	55	6
ZS204 0300312	3	0.3	4	12	55	6
ZS204 0300316	3	0.3	4	16	55	6
ZS204 0400212	4	0.2	5	12	55	6
ZS204 0400312	4	0.3	5	12	55	6
ZS204 0400316	4	0.3	5	16	55	6
ZS204 0400320	4	0.3	5	20	55	6
ZS204 0400512	4	0.5	5	12	55	6
ZS204 0400516	4	0.5	5	16	55	6
ZS204 0400520	4	0.5	5	20	55	6
ZS204 0401012	4	1	5	12	55	6
ZS204 0500116	5	0.1	6	16	60	6
ZS204 0500216	5	0.2	6	16	60	6
ZS204 0500316	5	0.3	6	16	60	6
ZS204 0500516	5	0.5	6	16	60	6
ZS204 0501016	5	1	6	16	60	6

▶ 적용 피삭재

○ : 적합 ◎ : 매우 적합

H		P			K	N			M	S
열처리강		탄소강	합금강	프리하든강	주철	동	흑연	알루미늄	스테인리스	내열합금
SKD61 ~HRc55	SKD11 HRc55~	~HB225	HB225 ~325	HRc30~50	~FCD500					
◎	◎		○	○						

ZS204 4날 벡 라디우스 엔드밀

Endmill

품목코드	DC	RE	APMX	LU	OAL	DCONMS
	날경	Corner R	날장	유효장	전장	자루경
ZS204 0600120	6	0.1	7	20	60	6
ZS204 0600220	6	0.2	7	20	60	6
ZS204 0600320	6	0.3	7	20	60	6
ZS204 0600520	6	0.5	7	20	60	6
ZS204 0601020	6	1	7	20	60	6
ZS204 0601520	6	1.5	7	20	60	6
ZS204 0800125	8	0.1	9	25	60	8
ZS204 0800225	8	0.2	9	25	60	8
ZS204 0800325	8	0.3	9	25	60	8
ZS204 0800525	8	0.5	9	25	60	8
ZS204 0801025	8	1	9	25	60	8
ZS204 0801525	8	1.5	9	25	60	8
ZS204 0802025	8	2	9	25	60	8
ZS204 1000232	10	0.2	11	32	75	10
ZS204 1000332	10	0.3	11	32	75	10
ZS204 1000532	10	0.5	11	32	75	10
ZS204 1001032	10	1	11	32	75	10
ZS204 1001532	10	1.5	11	32	75	10
ZS204 1002032	10	2	11	32	75	10
ZS204 1200238	12	0.2	12	38	75	12
ZS204 1200338	12	0.3	12	38	75	12
ZS204 1200538	12	0.5	12	38	75	12
ZS204 1201038	12	1	12	38	75	12
ZS204 1201538	12	1.5	12	38	75	12
ZS204 1202038	12	2	12	38	75	12

Zamus Star

E-Star

U-Wing

Zamus Thunder

X-Star

S-Wing

A-Wing

Standard

Copper-Mate

Gra-Mate

▶ 적용 피삭재

○ : 적합 ◎ : 매우 적합

H		P			K	N			M	S
열처리강		탄소강	합금강	프리하든강	주철	동	흑연	알루미늄	스테인리스	내열합금
SKD61 ~HRc55	SKD11 HRc55~	~HB225	HB225 ~325	HRc30~50	~FCD500					
◎	◎		○	○						

ZSLNR20

2날 롱 넥 래디우스 엔드밀

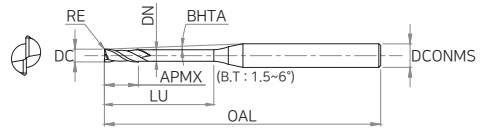

▶ 제품허용공차

날경(DC)		자루경
전 규격	0 ~ -0.015	h5

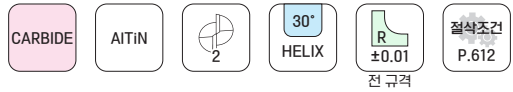
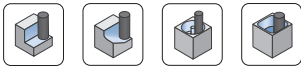

품목코드	DC	RE	APMX	LU	DN	OAL	DCONMS	BHTA	가공물 구배각별 유효길이				
	날경	반경 R	날장	유효장	유효경	전장	자루경	구배각	0.5°	1°	1.5°	2°	3°
ZSLNR20 02-0.5-005	0.2	0.05	0.15	0.5	0.17	50	4	11.4	0.9	1	1	1.1	12
ZSLNR20 02-1-005	0.2	0.05	0.15	1	0.17	50	4	10.9	1.6	1.7	1.9	2	2.3
ZSLNR20 02-1.5-005	0.2	0.05	0.15	1.5	0.17	50	4	10.3	2.1	2.3	2.5	2.7	3
ZSLNR20 02-2-005	0.2	0.05	0.15	2	0.17	50	4	9.9	2.8	3.1	3.4	3.6	4.1
ZSLNR20 03-1-005	0.3	0.05	0.25	1	0.27	50	4	10.8	1.4	1.5	1.6	1.7	1.9
ZSLNR20 03-1.5-005	0.3	0.05	0.25	1.5	0.27	50	4	10.3	2.1	2.3	2.5	2.7	3
ZSLNR20 03-2-005	0.3	0.05	0.25	2	0.27	50	4	9.8	2.7	2.9	3.1	3.3	3.6
ZSLNR20 03-2.5-005	0.3	0.05	0.25	2.5	0.27	50	4	9.4	3.2	3.5	3.7	3.9	4.3
ZSLNR20 03-3-005	0.3	0.05	0.25	3	0.27	50	4	9	3.9	4.3	4.6	4.9	5.4
ZSLNR20 04-1-005	0.4	0.05	0.3	1	0.37	50	4	10.8	1.4	1.5	1.6	1.7	1.9
ZSLNR20 04-1.5-005	0.4	0.05	0.3	1.5	0.37	50	4	10.3	2	2.1	2.2	2.3	2.5
ZSLNR20 04-2-005	0.4	0.05	0.3	2	0.37	50	4	9.8	2.7	2.9	3.1	3.3	3.6
ZSLNR20 04-2.5-005	0.4	0.05	0.3	2.5	0.37	50	4	9.4	3.2	3.5	3.7	3.9	4.3
ZSLNR20 04-3-005	0.4	0.05	0.3	3	0.37	50	4	9	3.8	4	4.3	4.5	4.9
ZSLNR20 04-3.5-005	0.4	0.05	0.3	3.5	0.37	50	4	8.6	4.3	4.6	4.9	5.1	5.5
ZSLNR20 04-4-005	0.4	0.05	0.3	4	0.37	50	4	8.3	5	5.4	5.8	6.1	6.6
ZSLNR20 04-2-01	0.4	0.1	0.3	2	0.37	50	4	9.8	2.7	2.9	3.1	3.3	3.6
ZSLNR20 04-3-01	0.4	0.1	0.3	3	0.37	50	4	9	3.8	4	4.3	4.5	4.9
ZSLNR20 04-4-01	0.4	0.1	0.3	4	0.37	50	4	8.3	5	5.4	5.8	6.1	6.6
ZSLNR20 05-1-005	0.5	0.05	0.35	1	0.47	50	4	10.8	1.4	1.5	1.6	1.7	1.9

▶ 적용 피삭재

○ : 적합 ◎ : 매우 적합

H		P			K	N			M	S
열처리강		탄소강	합금강	프리하든강	주철	동	흑연	알루미늄	스테인리스	내열합금
SKD61 ~HRc55	SKD11 HRc55~	~HB225	HB225 ~325	HRc30~50	~FCD500					
◎	◎		○	○						

ZSLNR20 2날 롱 넥 래디우스 엔드밀

Endmill

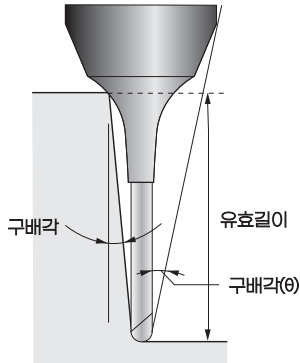

※ 표시된 유효길이는 공작물과의 간섭을 막기 위한 기본 값입니다.
가공환경의 적절한 제어가 필요합니다.

품목코드	DC	RE	APMX	LU	DN	OAL	DCONMS	BHTA	가공용 구배각별 유효길이				
	날경	반경 R	날장	유효장	유효경	전장	자루경	구배각	0.5°	1°	1.5°	2°	3°
ZSLNR20 05-2-005	0.5	0.05	0.35	2	0.47	50	4	9.7	2.5	2.6	2.8	2.9	3.1
ZSLNR20 05-3-005	0.5	0.05	0.35	3	0.47	50	4	8.9	3.8	4	4.3	4.5	4.9
ZSLNR20 05-4-005	0.5	0.05	0.35	4	0.47	50	4	8.2	4.8	5.2	5.4	5.7	6.1
ZSLNR20 05-5-005	0.5	0.05	0.35	5	0.47	50	4	7.6	6.1	6.6	6.9	7.3	7.8
ZSLNR20 05-6-005	0.5	0.05	0.35	6	0.47	50	4	7	7.2	7.7	8.1	8.4	9
ZSLNR20 05-1-01	0.5	0.1	0.35	1	0.47	50	4	10.8	1.4	1.5	1.6	1.7	1.9
ZSLNR20 05-2-01	0.5	0.1	0.35	2	0.47	50	4	9.8	2.5	2.6	2.8	2.9	3.1
ZSLNR20 05-3-01	0.5	0.1	0.35	3	0.47	50	4	8.9	3.8	4	4.3	4.5	4.9
ZSLNR20 05-4-01	0.5	0.1	0.35	4	0.47	50	4	8.2	4.8	5.2	5.4	5.7	6.1
ZSLNR20 05-5-01	0.5	0.1	0.35	5	0.47	50	4	7.6	6.1	6.5	6.9	7.2	7.8
ZSLNR20 05-6-01	0.5	0.1	0.35	6	0.47	50	4	7.1	7.2	7.7	8.1	8.4	9
ZSLNR20 06-2-01	0.6	0.1	0.4	2	0.57	50	4	9.7	2.5	2.6	2.8	2.9	3.1
ZSLNR20 06-4-01	0.6	0.1	0.4	4	0.57	50	4	8.1	4.8	5.2	5.4	5.7	6.1
ZSLNR20 06-6-01	0.6	0.1	0.4	6	0.57	50	4	7	7.2	7.7	8.1	8.4	9
ZSLNR20 06-8-01	0.6	0.1	0.4	8	0.57	50	4	6.1	9.3	9.9	10.3	10.7	11
ZSLNR20 06-10-01	0.6	0.1	0.4	10	0.57	50	4	5.5	11.5	12.1	12.5	13	13.7
ZSLNR20 08-4-01	0.8	0.1	0.5	4	0.77	50	4	8	4.8	5.2	5.4	5.7	6.1
ZSLNR20 08-6-01	0.8	0.1	0.5	6	0.77	50	4	6.8	7	7.4	7.7	7.9	8.4
ZSLNR20 08-8-01	0.8	0.1	0.5	8	0.77	50	4	5.9	9.3	9.9	10.3	10.7	11.4
ZSLNR20 08-12-01	0.8	0.1	0.5	12	0.77	50	4	4.7	13.6	14.2	14.7	15.2	16

▶ 적용 피삭재

○ : 적합 ◎ : 매우 적합

H		P			K	N			M	S
열처리강		탄소강	합금강	프리하트강	주철	동	흑연	알루미늄	스테인리스	내열합금
SKD61 ~HRc55	SKD11 HRc55~	~HB225	HB225 ~325	HRc30~50	~FCD500					
◎	◎		○	○						

ZSLNR20 2날 롱 넥 래디우스 엔드밀

Endmill

품목코드	DC	RE	APMX	LU	DN	OAL	DCONMS	BHTA	가공물 구배각별 유효길이				
	날경	반경 R	날장	유효장	유효경	전장	자루경	구배각	0.5°	1°	1.5°	2°	3°
ZSLNR20 08-4-02	0.8	0.2	0.5	4	0.77	50	4	8	4.8	5.1	5.4	5.6	6.1
ZSLNR20 08-6-02	0.8	0.2	0.5	6	0.77	50	4	6.9	7	7.3	7.7	7.9	8.4
ZSLNR20 10-4-01	1	0.1	0.8	4	0.94	50	4	7.7°	4.7	4.9	5.1	5.2	5.5
ZSLNR20 10-6-01	1	0.1	0.8	6	0.94	50	4	6.6°	7.1	7.4	7.7	8	8.5
ZSLNR20 10-8-01	1	0.1	0.8	8	0.94	50	4	5.7°	9.2	9.6	9.9	10.2	10.8
ZSLNR20 10-10-01	1	0.1	0.8	10	0.94	50	4	5.1°	11.6	12.1	12.6	13	13.7
ZSLNR20 10-4-02	1	0.2	0.8	4	0.94	50	4	7.8°	4.7	4.9	5.1	5.2	5.5
ZSLNR20 10-6-02	1	0.2	0.8	6	0.94	50	4	6.6°	7.1	7.4	7.7	8	8.5
ZSLNR20 10-8-02	1	0.2	0.8	8	0.94	50	4	5.8°	9.2	9.6	9.9	10.2	10.8
ZSLNR20 10-10-02	1	0.2	0.8	10	0.94	50	4	5.1°	11.6	12.1	12.6	13	13.7
ZSLNR20 10-6-03	1	0.3	0.8	6	0.94	50	4	6.7°	7.1	7.4	7.7	8	8.4
ZSLNR20 10-10-03	1	0.3	0.8	10	0.94	50	4	5.1°	11.5	12.1	12.6	13	13.7
ZSLNR20 10-12-01	1	0.1	0.8	12	0.94	55	4	4.5°	13.7	14.3	14.8	15.3	16
ZSLNR20 10-12-02	1	0.2	0.8	12	0.94	55	4	4.6°	13.7	14.3	14.8	15.2	16
ZSLNR20 10-16-01	1	0.1	0.8	16	0.94	60	4	3.8°	17.9	18.6	19.2	19.7	21.3
ZSLNR20 10-20-01	1	0.1	0.8	20	0.94	60	4	3.2°	22	22.8	23.5	24	26.7
ZSLNR20 10-16-02	1	0.2	0.8	16	0.94	60	4	3.8°	17.9	18.6	19.2	19.7	21.3
ZSLNR20 10-20-02	1	0.2	0.8	20	0.94	60	4	3.2°	22	22.8	23.5	24	26.6
ZSLNR20 10-16-03	1	0.3	0.8	16	0.94	60	4	3.8°	17.9	18.6	19.1	19.6	21.3
ZSLNR20 10-20-03	1	0.3	0.8	20	0.94	60	4	3.2°	22	22.8	23.5	24	26.6
ZSLNR20 15-4-01	1.5	0.1	1.35	4	1.42	50	4	7.2	4.8	4.9	5.1	5.3	5.5
ZSLNR20 15-8-01	1.5	0.1	1.35	8	1.42	50	4	5.2	9.2	9.6	10	10.3	10.8
ZSLNR20 15-12-01	1.5	0.1	1.35	12	1.42	55	4	4	13.4	13.9	14.3	14.7	16.1
ZSLNR20 15-15-01	1.5	0.1	1.35	15	1.42	55	4	3.5	16.9	17.6	18.1	18.6	20.1
ZSLNR20 15-20-01	1.5	0.1	1.35	20	1.42	60	4	2.8	22.1	22.9	23.5	24.1	-
ZSLNR20 15-4-02	1.5	0.2	1.35	4	1.42	50	4	7.3	4.7	4.9	5.1	5.3	5.5
ZSLNR20 15-8-02	1.5	0.2	1.35	8	1.42	50	4	5.2	9.2	9.6	10	10.3	10.8
ZSLNR20 15-12-02	1.5	0.2	1.35	12	1.42	55	4	4.1	13.4	13.9	14.3	14.7	16.1
ZSLNR20 15-15-02	1.5	0.2	1.35	15	1.42	55	4	3.5	16.9	17.5	18.1	18.6	20
ZSLNR20 15-20-02	1.5	0.2	1.35	20	1.42	60	4	2.8	22.1	22.9	23.5	24.1	-
ZSLNR20 15-8-03	1.5	0.3	1.35	8	1.42	50	4	5.2	9.2	9.6	10	10.3	10.8
ZSLNR20 15-15-03	1.5	0.3	1.35	15	1.42	55	4	3.5	16.9	17.5	18.1	18.6	20
ZSLNR20 15-20-03	1.5	0.3	1.35	20	1.42	60	4	2.8	22.1	22.9	23.5	24	-
ZSLNR20 20-6-02	2	0.2	1.7	6	1.92	50	4	5.4	6.8	7.1	7.3	7.5	8.1

▶ 적용 피삭재

○ : 적합 ◎ : 매우 적합

H		P			K	N			M	S
열처리강		탄소강	합금강	프리하든강	주철	동	흑연	알루미늄	스테인리스	내열합금
SKD61 ~HRc55	SKD11 HRc55~	~HB225	HB225 ~325	Hrc30~50	~FCD500					
◎	◎		○	○						

ZSLNR20 2날 룡 넥 래디우스 엔드밀

Endmill

품목코드	DC	RE	APMX	LU	DN	OAL	DCONMS	BHTA	가공물 구배각별 유효길이				
	날경	반경 R	날장	유효장	유효경	전장	자루경	구배각	0.5°	1°	1.5°	2°	3°
ZSLNR20 20-8-02	2	0.2	1.7	8	1.92	50	4	4.6	8.9	9.2	9.4	9.7	10.8
ZSLNR20 20-12-02	2	0.2	1.7	12	1.92	55	4	3.5	13.4	13.9	14.3	14.7	16.1
ZSLNR20 20-16-02	2	0.2	1.7	16	1.92	55	4	2.8	17.6	18.1	18.6	19.3	-
ZSLNR20 20-20-02	2	0.2	1.7	20	1.92	60	4	2.4	22.1	22.9	23.5	24.1	-
ZSLNR20 20-25-02	2	0.2	1.7	25	1.92	65	4	2	27.3	28.2	28.8	-	-
ZSLNR20 20-30-02	2	0.2	1.7	30	1.92	70	4	1.7	32.5	33.4	34.4	-	-
ZSLNR20 20-8-03	2	0.3	1.7	8	1.92	50	4	4.6	8.9	9.2	9.4	9.7	10.7
ZSLNR20 20-16-03	2	0.3	1.7	16	1.92	55	4	2.8	17.6	18.1	18.6	19.3	-
ZSLNR20 20-20-03	2	0.3	1.7	20	1.92	60	4	2.4	22.1	22.9	23.5	24	-
ZSLNR20 20-6-05	2	0.5	1.7	6	1.92	50	4	5.5	6.8	7.1	7.3	7.4	8
ZSLNR20 20-8-05	2	0.5	1.7	8	1.92	50	4	4.7	8.9	9.2	9.4	9.6	10.7
ZSLNR20 20-12-05	2	0.5	1.7	12	1.92	55	4	3.5	13.4	13.9	14.3	14.6	16
ZSLNR20 20-16-05	2	0.5	1.7	16	1.92	55	4	2.9	17.6	18.1	18.6	19.2	-
ZSLNR20 20-20-05	2	0.5	1.7	20	1.92	60	4	2.4	22.1	22.9	23.5	24	-
ZSLNR20 20-25-05	2	0.5	1.7	25	1.92	65	4	2	27.3	28.1	28.8	-	-
ZSLNR20 20-30-05	2	0.5	1.7	30	1.92	70	4	1.7	32.5	33.4	34.3	-	-
ZSLNR20 20-8-08	2	0.8	1.7	8	1.92	50	4	4.8	8.9	9.2	9.4	9.6	10.6
ZSLNR20 20-16-08	2	0.8	1.7	16	1.92	55	4	2.9	17.6	18.1	18.6	19.2	-
ZSLNR20 20-20-08	2	0.8	1.7	20	1.92	60	4	2.4	22.1	22.8	23.5	24	-
ZSLNR20 30-8-02	3	0.2	2.5	8	2.86	55	6	5.7	9	9.3	9.5	9.9	10.9
ZSLNR20 30-12-02	3	0.2	2.5	12	2.86	60	6	4.5	13.1	13.5	14	14.7	16.2
ZSLNR20 30-16-02	3	0.2	2.5	16	2.86	60	6	3.8	17.7	18.2	18.7	19.5	21.6
ZSLNR20 30-20-02	3	0.2	2.5	20	2.86	65	6	3.2	21.8	22.4	23.1	24.2	26.9
ZSLNR20 30-30-02	3	0.2	2.5	30	2.86	75	6	2.4	32.6	33.5	34.5	36.2	-
ZSLNR20 30-35-02	3	0.2	2.5	35	2.86	80	6	2.1	37.7	38.7	40.2	42.2	-
ZSLNR20 30-8-03	3	0.3	2.5	8	2.86	55	6	5.7	9	9.3	9.5	9.9	10.9
ZSLNR20 30-16-03	3	0.3	2.5	16	2.86	60	6	3.8	17.7	18.2	18.7	19.4	21.5
ZSLNR20 30-20-03	3	0.3	2.5	20	2.86	65	6	3.2	21.8	22.4	23.1	24.2	26.8
ZSLNR20 30-30-03	3	0.3	2.5	30	2.86	75	6	2.4	32.6	33.5	34.5	36.2	-
ZSLNR20 30-8-05	3	0.5	2.5	8	2.86	55	6	5.8	9	9.3	9.5	9.8	10.8
ZSLNR20 30-12-05	3	0.5	2.5	12	2.86	60	6	4.6	13.1	13.5	13.9	14.6	16.2
ZSLNR20 30-16-05	3	0.5	2.5	16	2.86	60	6	3.8	17.7	18.2	18.7	19.4	21.5
ZSLNR20 30-20-05	3	0.5	2.5	20	2.86	65	6	3.2	21.8	22.4	23.1	24.2	26.8
ZSLNR20 30-30-05	3	0.5	2.5	30	2.86	75	6	2.4	32.6	33.5	34.5	36.1	-
ZSLNR20 30-35-05	3	0.5	2.5	35	2.86	80	6	2.1	37.7	38.7	40.2	42.1	-

Zamus Star
E-Star
U-Wing
Zamus Thunder
X-Star
S-Wing
A-Wing
Standard
Copper-Mate
Gra-Mate

▶ 적용 피삭재

○ : 적합 ◎ : 매우 적합

H		P			K	N			M	S
열처리강		탄소강	합금강	프리하트강	주철	동	흑연	알루미늄	스테인리스	내열합금
SKD61 ~HRc55	SKD11 HRc55~	~HB225	HB225 ~325	HRc30~50	~FCD500					
◎	◎		○	○						

ZSTNR20 2날 테이퍼 넥 래디우스 엔드밀

Endmill

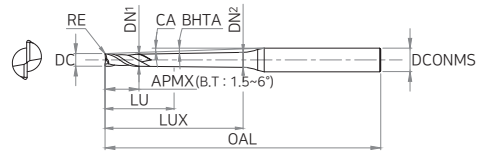
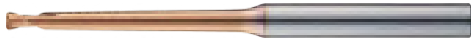

Zamus Star

E-Star

▶ 제품허용공차

날경(DC)		자루경
전 규격	0 ~ -0.015	h5

U-Wing

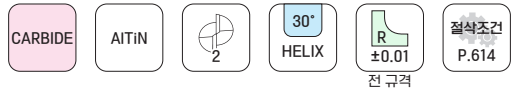
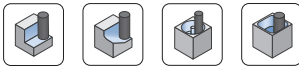

Zamus Thunder

품목코드	DC	RE	APMX	LUX	CA	DN ¹	DN ²	OAL	DCONMS	LU	BHTA	가공물 구배각별 유효길이				
	날경	반경 R	날장	유효장	테이퍼각	유효경	대단경	전장	자루경	날경	구배각	0.5°	1°	1.5°	2°	3°
ZSTNR20 02-2-09005	0.2	0.05	0.15	2	0.9	0.17	0.23	50	4	1.1	10	x	2.8	3.1	3.4	3.9
ZSTNR20 04-4-09005	0.4	0.05	0.3	4	0.9	0.37	0.49	50	4	1.25	8.4	x	4.9	5.3	5.7	6.3
ZSTNR20 04-5-09005	0.4	0.05	0.3	5	0.9	0.37	0.52	50	4	1.25	7.8	x	5.9	6.4	6.8	7.5
ZSTNR20 04-4-0901	0.4	0.1	0.3	4	0.9	0.37	0.49	50	4	1.25	8.5	x	4.9	5.3	5.7	6.3
ZSTNR20 04-5-0901	0.4	0.1	0.3	5	0.9	0.37	0.52	50	4	1.25	7.9	x	5.9	6.4	6.8	7.5
ZSTNR20 05-5-0901	0.5	0.1	0.35	5	0.9	0.47	0.62	50	4	1.3	7.8	x	5.9	6.4	6.8	7.5
ZSTNR20 05-8-0901	0.5	0.1	0.35	8	0.9	0.47	0.71	50	4	1.3	6.4	x	9	9.7	10.2	11
ZSTNR20 05-10-0901	0.5	0.1	0.35	10	0.9	0.47	0.77	55	4	1.3	5.8	x	11	11.8	12.4	13.2
ZSTNR20 06-12-0901	0.6	0.1	0.4	12	0.9	0.57	0.93	55	4	1.35	5.1	x	13	13.9	14.5	15.5
ZSTNR20 06-15-0901	0.6	0.1	0.4	15	0.9	0.57	1.03	55	4	1.35	4.5	x	16.1	17.1	17.8	18.8
ZSTNR20 08-6-0402	0.8	0.2	0.5	6	0.4	0.77	0.85	50	4	2.64	7	6.6	7.1	7.5	7.8	8.3
ZSTNR20 08-12-0902	0.8	0.2	0.5	12	0.9	0.77	1.13	55	4	1.45	5	x	13	13.9	14.5	15.5
ZSTNR20 10-8-0402	1	0.2	0.8	8	0.4	0.94	1.04	55	6	5.09	7.4	8.8	9.3	9.7	10.1	10.6
ZSTNR20 10-10-0902	1	0.2	0.8	10	0.9	0.94	1.23	55	6	5.09	6.8	x	11.2	11.9	12.4	13.3
ZSTNR20 10-15-0902	1	0.2	0.8	15	0.9	0.94	1.39	60	6	2.7	5.6	x	16.3	17.2	17.8	18.8
ZSTNR20 10-20-0902	1	0.2	0.8	20	0.9	0.94	1.54	65	6	2.7	4.8	x	21.3	22.4	23.2	24.7
ZSTNR20 10-25-0902	1	0.2	0.8	25	0.9	0.94	1.7	70	6	2.7	4.1	x	26.4	27.6	28.5	30.9
ZSTNR20 10-30-0902	1	0.2	0.8	30	0.9	0.94	1.86	75	6	2.7	3.7	x	31.5	32.8	33.7	37
ZSTNR20 10-35-0902	1	0.2	0.8	35	0.9	0.94	2.02	80	6	2.7	3.3	x	36.5	38	39	43.2
ZSTNR20 10-8-0403	1	0.3	0.8	8	0.4	0.94	1.04	55	6	2.7	7.4	8.8	9.3	9.7	10	10.6

Copper -Mate

Gra -Mate

▶ 적용 피삭재

○ : 적합 ◎ : 매우 적합

H		P			K	N			M	S
열처리강		탄소강	합금강	프리하든강	주철	동	흑연	알루미늄	스테인리스	내열합금
SKD61 ~HRc55	SKD11 HRc55~	~HB225	HB225 ~325	HRc30~50	~FCD500					
◎	◎		○	○						

ZSTNR20

2날 테이퍼 넥 라디우스 엔드밀

Endmill

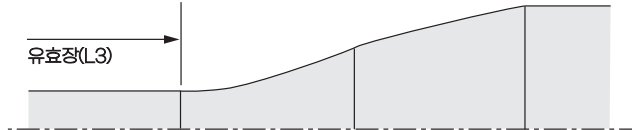
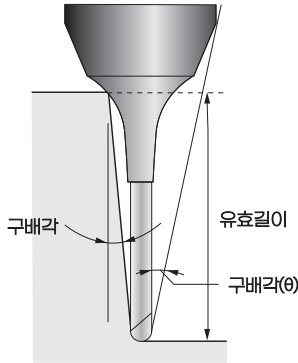

※ 표시된 유효길이는 공작물과의 간섭을 막기 위한 기본 값입니다.
가공환경의 적절한 제어가 필요합니다.

Zamus Star

E-Star

U-Wing

Zamus Thunder

X-Star

S-Wing

A-Wing

Standard

Copper-Mate

Gra-Mate

품목코드	DC	RE	APMX	LUX	CA	DN ¹	DN ²	OAL	DCONMS	LU	BHTA	가공용 구배각별 유효길이				
	날경	반경 R	날장	유효장	테이퍼각	유효경	대단경	전장	자루경	날경	구배각	0.5°	1°	1.5°	2°	3°
ZSTNR20 10-15-0903	1	0.3	0.8	15	0.9	0.94	1.39	60	6	2.7	5.6	x	16.3	17.2	17.8	18.8
ZSTNR20 10-25-0903	1	0.3	0.8	25	0.9	0.94	1.7	70	6	2.7	4.2	x	26.4	27.6	28.5	30.8
ZSTNR20 10-30-0903	1	0.3	0.8	30	0.9	0.94	1.86	75	6	2.7	3.7	x	31.5	32.8	33.7	37
ZSTNR20 15-10-0402	1.5	0.2	1.35	10	0.4	1.42	1.54	55	6	7.07	6.4	11	11.5	11.9	12.3	13
ZSTNR20 15-15-0902	1.5	0.2	1.35	15	0.9	1.42	1.85	60	6	7.07	5.3	x	16.4	17.3	17.9	18.9
ZSTNR20 15-20-0902	1.5	0.2	1.35	20	0.9	1.42	2.01	65	6	3.89	4.5	x	21.5	22.5	23.2	24.9
ZSTNR20 15-25-0902	1.5	0.2	1.35	25	0.9	1.42	2.16	70	6	3.89	3.9	x	26.6	27.7	28.5	31
ZSTNR20 15-30-0902	1.5	0.2	1.35	30	0.9	1.42	2.32	75	6	3.89	3.4	x	31.6	32.9	33.8	37.1
ZSTNR20 15-10-0403	1.5	0.3	1.35	10	0.4	1.42	1.54	55	6	3.89	6.4	11	11.5	11.9	12.3	13
ZSTNR20 15-20-0903	1.5	0.3	1.35	20	0.9	1.42	2.01	65	6	3.89	4.5	x	21.5	22.5	23.2	24.8
ZSTNR20 15-25-0903	1.5	0.3	1.35	25	0.9	1.42	2.16	70	6	3.89	3.9	x	26.5	27.7	28.5	31
ZSTNR20 15-30-0903	1.5	0.3	1.35	30	0.9	1.42	2.32	75	6	3.89	3.4	x	31.6	32.9	33.8	37.1
ZSTNR20 20-30-0902	2	0.2	1.7	30	0.9	1.92	2.81	70	6	7.42	3.1	x	31.6	32.9	33.8	37.2
ZSTNR20 20-40-0902	2	0.2	1.7	40	0.9	1.92	3.12	80	6	7.42	2.5	x	41.8	43.3	44.6	-
ZSTNR20 20-50-0902	2	0.2	1.7	50	0.9	1.92	3.44	90	6	7.42	2.1	x	51.9	53.6	55.7	-
ZSTNR20 20-12-0403	2	0.3	1.7	12	0.4	1.92	2.06	55	6	7.42	5.5	13	13.6	14.1	14.5	15.6
ZSTNR20 20-20-0903	2	0.3	1.7	20	0.9	1.92	2.5	65	6	4.24	4.1	x	21.5	22.5	23.2	24.9
ZSTNR20 20-30-0903	2	0.3	1.7	30	0.9	1.92	2.81	70	6	4.24	3.1	x	31.6	32.9	33.8	37.1
ZSTNR20 20-40-0903	2	0.3	1.7	40	0.9	1.92	3.12	80	6	4.24	2.5	x	41.7	43.3	44.6	-
ZSTNR20 20-50-0903	2	0.3	1.7	50	0.9	1.92	3.44	90	6	4.24	2.1	x	51.8	53.6	55.7	-

▶ 적용 피삭재

○ : 적합 ◎ : 매우 적합

H		P			K	N			M	S
열처리강		탄소강	합금강	프리하트강	주철	동	흑연	알루미늄	스테인리스	내열합금
SKD61 ~HRc55	SKD11 HRc55~	~HB225	HB225 ~325	HRc30~50	~FCD500					
◎	◎		○	○						

ZSTNR20 2날 테이퍼 넥 래디우스 엔드밀

Endmill

품목코드	DC	RE	APMX	LUX	CA	DN ¹	DN ²	OAL	DCONMS	LU	BHTA	가공물 구배각별 유효길이				
	날경	반경 R	날장	유효장	테이퍼각	유효경	대단경	전장	자루경	날경	구배각	0.5°	1°	1.5°	2°	3°
ZSTNR20 20-8-0405	2	0.5	1.7	8	0.4	1.92	2.01	50	6	4.24	6.8	8.7	9	9.3	9.5	10.4
ZSTNR20 20-12-0405	2	0.5	1.7	12	0.4	1.92	2.06	55	6	4.24	5.6	13	13.6	14.1	14.4	15.5
ZSTNR20 20-16-0405	2	0.5	1.7	16	0.4	1.92	2.12	60	6	4.24	4.7	17	17.8	18.3	18.7	20.7
ZSTNR20 20-20-0905	2	0.5	1.7	20	0.9	1.92	2.5	65	6	4.24	4.2	x	21.5	22.5	23.2	24.8
ZSTNR20 20-25-0905	2	0.5	1.7	25	0.9	1.92	2.65	65	6	4.24	3.6	x	26.6	27.7	28.5	30.9
ZSTNR20 20-30-0905	2	0.5	1.7	30	0.9	1.92	2.81	70	6	4.24	3.1	x	31.6	32.9	33.8	37.1
ZSTNR20 20-40-0905	2	0.5	1.7	40	0.9	1.92	3.12	80	6	4.24	2.5	x	41.7	43.2	44.6	-
ZSTNR20 20-50-0905	2	0.5	1.7	50	0.9	1.92	3.44	90	6	4.24	2.1	x	51.8	53.6	55.6	-
ZSTNR20 30-40-0902	3	0.2	2.5	40	0.9	2.86	4.04	80	6	6.95	2	x	42	43.4	-	-
ZSTNR20 30-50-0902	3	0.2	2.5	50	0.9	2.86	4.35	90	6	6.95	1.6	x	52.1	53.7	-	-
ZSTNR20 30-60-0902	3	0.2	2.5	60	0.9	2.86	4.67	100	6	6.95	1.4	x	62.2	-	-	-
ZSTNR20 30-40-0903	3	0.3	2.5	40	0.9	2.86	4.04	80	6	6.95	2	x	42	43.4	-	-
ZSTNR20 30-50-0903	3	0.3	2.5	50	0.9	2.86	4.35	90	6	6.95	1.7	x	52.1	53.7	-	-
ZSTNR20 30-60-0903	3	0.3	2.5	60	0.9	2.86	4.67	100	6	6.95	1.4	x	62.2	-	-	-
ZSTNR20 30-40-0905	3	0.5	2.5	40	0.9	2.86	4.04	80	6	6.95	2	x	42	43.4	-	-
ZSTNR20 30-50-0905	3	0.5	2.5	50	0.9	2.86	4.35	90	6	6.95	1.7	x	52.1	53.7	-	-
ZSTNR20 30-60-0905	3	0.5	2.5	60	0.9	2.86	4.67	100	6	6.95	1.4	x	62.1	-	-	-

Zamus Star

E-Star

U-Wing

Zamus Thunder

X-Star

S-Wing

A-Wing

Standard

Copper -Mate

Gra -Mate

▶ 적용 피삭재

○ : 적합 ◎ : 매우 적합

H		P			K	N			M	S
열처리강		탄소강	합금강	프리하든강	주철	동	흑연	알루미늄	스테인리스	내열합금
SKD61 ~HRc55	SKD11 HRc55~	~HB225	HB225 ~325	HRc30~50	~FCD500					
◎	◎		○	○						

ZSPM4 4날 고이송용 벡 래디우스 엔드밀

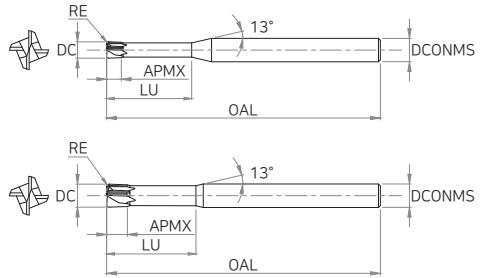

▶ 제품허용공차

날경(DC)		자루경
전 규격	0 ~ -0.02	h5

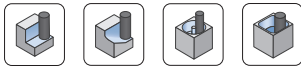

품목코드	DC	RE	APMX	LU	OAL	DCONMS
	날경	Corner R	날장	유효장	전장	자루경
ZSPM4 030-05	3	0.5	1.2	8	50	6
ZSPM4 040-05	4	0.5	1.5	10	50	6
ZSPM4 060-05	6	0.5	2.5	12	60	6
ZSPM4 060-10	6	1	2.5	12	60	6
ZSPM4 060-15	6	1.5	2.5	12	60	6
ZSPM4 060-15L	6	1.5	2.5	12	90	6
ZSPM4 080-10	8	1	3.5	16	60	8
ZSPM4 080-20	8	2	3.5	16	60	8
ZSPM4 080-20L	8	2	3.5	16	100	8
ZSPM4 100-10	10	1	4	20	70	10
ZSPM4 100-20	10	2	4	20	70	10
ZSPM4 100-20L	10	2	4	20	100	10
ZSPM4 120-20	12	2	5	25	80	12
ZSPM4 120-30	12	3	5	25	80	12
ZSPM4 120-30L	12	3	5	25	110	12

▶ 적용 피삭재

○ : 적합 ◎ : 매우 적합

H		P			K	N			M	S
열처리강		탄소강	합금강	프리하든강	주철	동	흑연	알루미늄	스테인리스	내열합금
SKD61 ~HRc55	SKD11 HRc55~	~HB225	HB225 ~325	HRc30~50	~FCD500					
◎	◎		○	○						

DB702 2날 넥 볼 엔드밀

Endmill

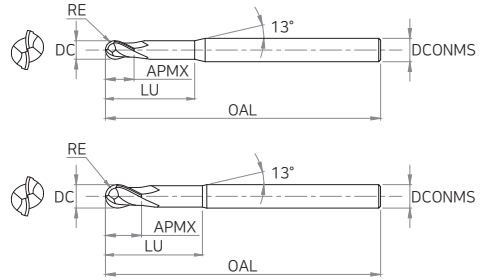

Zamus Star

E-Star

▶ 제품허용공차

날경(DC)		자루경
전 규격	0 ~ -0.02	h5

U-Wing



CARBIDE AITIN 2 30° HELIX ±0.005 R3 이하 ±0.01 R3 초과 절삭조건 P.616

Zamus Thunder

품목코드	DC	RE	APMX	LU	OAL	DCONMS
	날경	반경 R	날장	유효장	전장	자루경
DB702 001	0.1	0.05	0.15	-	40	4
DB702 002	0.2	0.1	0.3	-	40	4
DB702 003	0.3	0.15	0.5	-	40	4
DB702 004	0.4	0.2	0.6	-	40	4
DB702 005	0.5	0.25	0.7	-	40	4
DB702 006	0.6	0.3	0.9	-	40	4
DB702 007	0.7	0.35	1.1	-	40	4
DB702 008	0.8	0.4	1.2	-	40	4
DB702 009	0.9	0.45	1.4	-	40	4
DB702 010 S4	1	0.5	1.5	-	45	4
DB702 010	1	0.5	1.5	3	50	6
DB702 015 S4	1.5	0.75	2	-	45	4
DB702 015	1.5	0.75	2	4	50	6
DB702 020 S4	2	1	2.5	-	45	4
DB702 020	2	1	2.5	5	50	6
DB702 025	2.5	1.25	3	7	50	6
DB702 030S4	3	1.5	4	-	45	4

품목코드	DC	RE	APMX	LU	OAL	DCONMS
	날경	반경 R	날장	유효장	전장	자루경
DB702 030S	3	1.5	4	10	50	6
DB702 030	3	1.5	4	10	60	6
DB702 031	3	1.5	4	10	70	6
DB702 040 S4	4	2	5	-	45	4
DB702 040 S	4	2	5	10	50	6
DB702 040	4	2	5	10	60	6
DB702 041	4	2	5	10	70	6
DB702 050	5	2.5	6	12	60	6
DB702 060	6	3	7	12	60	6
DB702 061	6	3	7	12	90	6
DB702 080	8	4	9	15	70	8
DB702 081	8	4	9	15	100	8
DB702 100	10	5	11	25	75	10
DB702 101	10	5	11	25	100	10
DB702 120	12	6	12	25	80	12
DB702 121	12	6	12	25	110	12

X-Star

S-Wing

A-Wing

Standard

Copper-Mate

▶ 적용 피삭재

○ : 적합 ◎ : 매우 적합

H		P			K	N		M	S	
열처리강		탄소강	합금강	프리하든강	주철	동	흑연	알루미늄	스테인리스	내열합금
SKD61 ~HRc55	SKD11 HRc55~	~HB225	HB225 ~325	HRc30~50	~FCD500					
◎	◎		○	○						

DB703 3날 넥 볼 엔드밀

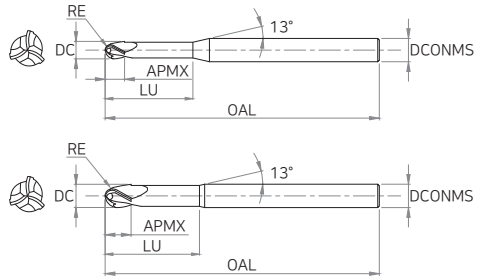

▶ 제품허용공차

날경(DC)		자루경
전 규격	0 ~ -0.015	h5



CARBIDE
AlTiN
3
30° HELIX
R ±0.005 R3 이하
R ±0.01 R3 초과
절삭조건 P.616

품목코드	DC	RE	APMX	LU	OAL	DCONMS
	날경	반경 R	날장	유효장	전장	자루경
DB703 025	2.5	1.25	3	7	50	6
DB703 030S	3	1.5	4	10	50	6
DB703 030	3	1.5	4	10	60	6
DB703 031	3	1.5	4	10	70	6
DB703 040S	4	2	5	10	50	6
DB703 040	4	2	5	10	60	6
DB703 041	4	2	5	10	70	6
DB703 050	5	2.5	6	12	60	6
DB703 060	6	3	7	12	60	6
DB703 061	6	3	7	12	90	6
DB703 080	8	4	9	15	70	8
DB703 081	8	4	9	15	100	8
DB703 100	10	5	11	25	75	10
DB703 101	10	5	11	25	100	10
DB703 120	12	6	12	25	80	12
DB703 121	12	6	12	25	110	12

▶ 적용 피삭재

○ : 적합 ◎ : 매우 적합

H		P			K	N			M	S
열처리강		탄소강	합금강	프리하든강	주철	동	흑연	알루미늄	스테인리스	내열합금
SKD61 ~HRc55	SKD11 HRc55~	~HB225	HB225 ~325	HRc30~50	~FCD500					
◎	◎		○	○						

- Endmill
- Zamus Star
- E-Star
- U-Wing
- Zamus Thunder
- X-Star
- S-Wing
- A-Wing
- Standard
- Copper-Mate
- Gra-Mate

DB712 2날 볼 엔드밀

Endmill

Zamus Star

E-Star

U-Wing

Zamus Thunder

X-Star

S-Wing

A-Wing

Standard

Copper -Mate

Gra -Mate

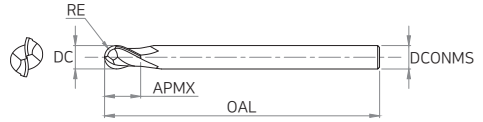
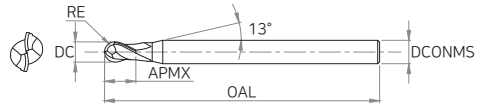

▶ 제품허용공차

날경(DC)		자루경
전 규격	0 ~ -0.02	h5

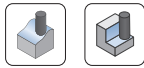

CARBIDE
AITIN
2
30° HELIX
R ±0.005 R3 이하
R ±0.01 R3 초과
절삭조건 P.616

품목코드	DC	RE	APMX	OAL	DCONMS
	날경	반경 R	날장	전장	자루경
DB712 010S	1	0.5	1.5	40	6
DB712 010S4	1	0.5	2.5	50	4
DB712 010	1	0.5	2.5	50	6
DB712 012	1.2	0.6	3	50	6
DB712 015S	1.5	0.75	2.5	40	6
DB712 015S4	1.5	0.75	4	50	4
DB712 015	1.5	0.75	4	50	6
DB712 020S	2	1	3	40	6
DB712 020S4	2	1	5	50	4
DB712 020	2	1	5	50	6
DB712 025	2.5	1.25	7	60	6
DB712 030S	3	1.5	4.5	50	6
DB712 030S4	3	1.5	8	60	4

품목코드	DC	RE	APMX	OAL	DCONMS
	날경	반경 R	날장	전장	자루경
DB712 030	3	1.5	8	60	6
DB712 040S	4	2	6	50	6
DB712 040	4	2	8	70	6
DB712 050S	5	2.5	7.5	50	6
DB712 050	5	2.5	10	80	6
DB712 060S	6	3	9	50	6
DB712 060	6	3	12	90	6
DB712 080S	8	4	12	50	8
DB712 081	8	4	14	100	8
DB712 100S	10	5	15	60	10
DB712 100	10	5	18	100	10
DB712 120S	12	6	18	60	12
DB712 120	12	6	22	110	12

▶ 적용 피삭재

○ : 적합 ◎ : 매우 적합

H		P			K	N			M	S
열처리강		탄소강	합금강	프리하든강	주철	동	흑연	알루미늄	스테인리스	내열합금
SKD61 ~HRc55	SKD11 HRc55~	~HB225	HB225 ~325	HRc30~50	~FCD500					
◎	◎		○	○						

DB734

4날 15도 헬릭스 볼 엔드밀

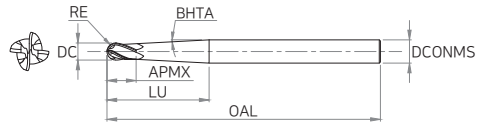

Endmill

▶ 제품허용공차

날경(DC)		자루경
전 규격	0 ~ -0.015	h5



CARBIDE
AITIN
4
15° HELIX
R ±0.01 전 규격
절삭조건 P.617

품목코드	DC	RE	APMX	LU	OAL	BHTA	DCONMS
	날경	반경 R	날장	유효장	전장	구배각	자루경
DB734 020-2.5	2	1	2	25	60	2.5	4
DB734 020-3.5	2	1	2	18	60	3.5	4
DB734 025-2.5	2.5	1.25	3	20	60	2.5	4
DB734 025-3.0	2.5	1.25	3	17	60	3	4
DB734 030-2.0	3	1.5	3	46	70	2	6
DB734 030-2.5	3	1.5	3	37	70	2.5	6
DB734 040-2.0	4	2	4	33	70	2	6
DB734 040-2.5	4	2	4	27	70	2.5	6
DB734 050-2.5	5	2.5	5	16	70	2.5	6
DB734 060-1.5	6	3	6	44	100	1.5	8
DB734 060-2.5	6	3	6	29	100	2.5	8
DB734 080-1.5	8	4	8	46	100	1.5	10
DB734 080-2.5	8	4	8	31	100	2.5	10
DB734 100-1.5	10	5	10	48	110	1.5	12
DB734 100-2.5	10	5	10	33	110	2.5	12

Zamus Star

E-Star

U-Wing

Zamus Thunder

X-Star

S-Wing

A-Wing

Standard

Copper-Mate

Gra-Mate

▶ 적용 피삭재

○ : 적합 ◎ : 매우 적합

H		P			K	N			M	S
열처리강		탄소강	합금강	프리하든강	주철	동	흑연	알루미늄	스테인리스	내열합금
SKD61 ~HRc55	SKD11 HRc55~	~HB225	HB225 ~325	HRc30~50	~FCD500					
◎	◎		○	○						

ZSLNB20

2날 롱 넥 볼 엔드밀

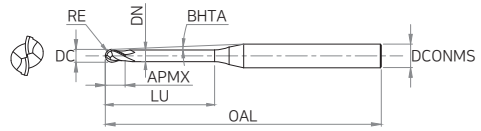

▶ 제품허용공차

날경(DC)		자루경
전 규격	0 ~ -0.015	h5

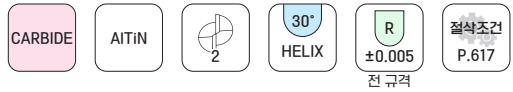

품목코드	DC	RE	APMX	LU	DN	OAL	DCONMS	BHTA	가공물 구배각별 유효길이				
	날경	반경 R	날장	유효장	유효경	전장	자루경	구배각	0.5°	1°	1.5°	2°	3°
ZSLNB20 01-0.2	0.1	0.05	0.08	0.2	0.08	45	4	11.8	0.3	0.3	0.3	0.4	0.4
ZSLNB20 01-0.3	0.1	0.05	0.08	0.3	0.08	45	4	11.7	0.4	0.4	0.5	0.5	0.5
ZSLNB20 01-0.5	0.1	0.05	0.08	0.5	0.08	45	4	11.4	0.6	0.7	0.7	0.7	0.8
ZSLNB20 02-0.5	0.2	0.1	0.15	0.5	0.17	50	4	11.5	1.2	1.3	1.5	1.6	2
ZSLNB20 02-1	0.2	0.1	0.15	1	0.17	50	4	10.9	1.7	1.9	2.1	2.3	2.7
ZSLNB20 02-1.5	0.2	0.1	0.15	1.5	0.17	50	4	10.4	2.3	2.5	2.8	3	3.4
ZSLNB20 02-2	0.2	0.1	0.15	2	0.17	50	4	9.9	2.8	3.1	3.4	3.6	4.1
ZSLNB20 02-2.5	0.2	0.1	0.15	2.5	0.17	50	4	9.5	3.4	3.7	4	4.2	4.7
ZSLNB20 02-3.0	0.2	0.1	0.15	3	0.17	50	4	9.1	3.9	4.3	4.6	4.9	5.4
ZSLNB20 03-1	0.3	0.15	0.25	1	0.27	50	4	10.9	1.7	1.9	2.1	2.3	5.4
ZSLNB20 03-1.5	0.3	0.15	0.25	1.5	0.27	50	4	10.4	2.3	2.5	2.7	3	3.4
ZSLNB20 03-2	0.3	0.15	0.25	2	0.27	50	4	9.9	2.8	3.1	3.4	3.6	4
ZSLNB20 03-2.5	0.3	0.15	0.25	2.5	0.27	50	4	9.5	3.4	3.7	4	4.2	4.7
ZSLNB20 03-3	0.3	0.15	0.25	3	0.27	50	4	9.1	3.9	4.3	4.6	4.8	5.3
ZSLNB20 04-1	0.4	0.2	0.3	1	0.37	50	4	11	1.7	1.9	2.1	2.3	2.7
ZSLNB20 04-1.5	0.4	0.2	0.3	1.5	0.37	50	4	10.4	2.3	2.5	2.7	2.9	3.4
ZSLNB20 04-2	0.4	0.2	0.3	2	0.37	50	4	9.9	2.8	3.1	3.4	3.6	4
ZSLNB20 04-2.5	0.4	0.2	0.3	2.5	0.37	50	4	9.5	3.4	3.7	4	4.2	4.7
ZSLNB20 04-3	0.4	0.2	0.3	3	0.37	50	4	9.1	3.9	4.3	4.6	4.8	5.3
ZSLNB20 04-3.5	0.4	0.2	0.3	3.5	0.37	50	4	8.7	4.5	4.8	5.2	5.4	6

▶ 적용 피삭재

○ : 적합 ◎ : 매우 적합

H		P			K	N			M	S
열처리강		탄소강	합금강	프리하든강	주철	동	흑연	알루미늄	스테인리스	내열합금
SKD61 ~HRc55	SKD11 HRc55~	~HB225	HB225 ~325	HRc30~50	~FCD500					
◎	◎		○	○						

ZSLNB20

2날 롱 넥 볼 엔드밀

Endmill

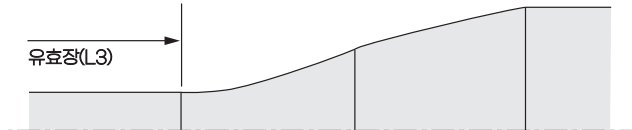
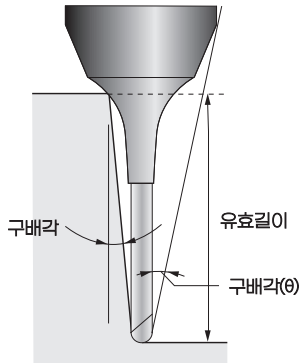

※ 표시된 유효길이는 공작물과의 간섭을 막기 위한 기본 값입니다.
가공환경의 적절한 제어가 필요합니다.

품목코드	DC	RE	APMX	LU	DN	OAL	DCONMS	BHTA	가공용 구배각별 유효길이				
	날경	반경 R	날장	유효장	유효경	전장	자루경	구배각	0.5°	1°	1.5°	2°	3°
ZSLNB20 04-4	0.4	0.2	0.3	4	0.37	50	4	8.3	5	5.4	5.7	6	6.6
ZSLNB20 04-4.5	0.4	0.2	0.3	4.5	0.37	50	4	8	5.6	6	6.3	6.6	7.2
ZSLNB20 05-1	0.5	0.25	0.35	1	0.47	50	4	11	1.7	1.9	2.1	2.3	2.6
ZSLNB20 05-2	0.5	0.25	0.35	2	0.47	50	4	9.9	2.8	3.1	3.3	3.6	4
ZSLNB20 05-3	0.5	0.25	0.35	3	0.47	50	4	9	3.9	4.3	4.6	4.8	5.3
ZSLNB20 05-4	0.5	0.25	0.35	4	0.47	50	4	8.3	5	5.4	5.7	6	6.6
ZSLNB20 05-5	0.5	0.25	0.35	5	0.47	50	4	7.7	6.1	6.5	6.9	7.2	7.8
ZSLNB20 05-6	0.5	0.25	0.35	6	0.47	50	4	7.1	7.2	7.6	8	8.4	9
ZSLNB20 05-8	0.5	0.25	0.35	8	0.47	50	4	6.3	9.3	9.9	10.3	10.7	11.4
ZSLNB20 06-1	0.6	0.3	0.4	1	0.57	50	4	11	1.7	1.9	2.1	2.3	2.6
ZSLNB20 06-2	0.6	0.3	0.4	2	0.57	50	4	9.9	2.8	3.1	3.3	3.6	4
ZSLNB20 06-3	0.6	0.3	0.4	3	0.57	50	4	9	3.9	4.3	4.5	4.8	5.3
ZSLNB20 06-4	0.6	0.3	0.4	4	0.57	50	4	8.3	5	5.4	5.7	6	6.6
ZSLNB20 06-5	0.6	0.3	0.4	5	0.57	50	4	7.6	6.1	6.5	6.9	7.2	7.8
ZSLNB20 06-6	0.6	0.3	0.4	6	0.57	50	4	7.1	7.2	7.6	8	8.4	9
ZSLNB20 06-7	0.6	0.3	0.4	7	0.57	50	4	6.6	8.3	8.8	9.2	9.5	10.2
ZSLNB20 06-8	0.6	0.3	0.4	8	0.57	50	4	6.2	9.3	9.9	10.3	10.7	11.4
ZSLNB20 06-9	0.6	0.3	0.4	9	0.57	50	4	5.8	10.4	10.9	11.4	11.8	12.5
ZSLNB20 06-10	0.6	0.3	0.4	10	0.57	50	4	5.5	11.4	12	12.5	12.9	13.7
ZSLNB20 06-12	0.6	0.3	0.4	12	0.57	50	4	5	13.6	14.2	14.7	15.2	16

▶ 적용 피삭재

○ : 적합 ◎ : 매우 적합

H		P			K	N			M	S
열처리강		탄소강	합금강	프리하트강	주철	동	흑연	알루미늄	스테인리스	내열합금
SKD61 ~HRc55	SKD11 HRc55~	~HB225	HB225 ~325	HRc30~50	~FCD500					
◎	◎		○	○						

Zamus Star
E-Star
U-Wing
Zamus Thunder
X-Star
S-Wing
A-Wing
Standard
Copper-Mate
Gra-Mate

ZSLNB20

2날 롱 넥 볼 엔드밀

Endmill

품목코드	DC	RE	APMX	LU	DN	OAL	DCONMS	BHTA	가공물 구배각별 유효길이				
	날경	반경 R	날장	유효장	유효경	전장	자루경	구배각	0.5°	1°	1.5°	2°	3°
ZSLNB20 08-2	0.8	0.4	0.5	2	0.77	50	4	9.9	2.8	3.1	3.3	3.5	4
ZSLNB20 08-4	0.8	0.4	0.5	4	0.77	50	4	8.2	5	5.4	5.7	6	6.5
ZSLNB20 08-5	0.8	0.4	0.5	5	0.77	50	4	7.5	6.1	6.5	6.9	7.2	7.8
ZSLNB20 08-6	0.8	0.4	0.5	6	0.77	50	4	7	7.2	7.6	8	8.4	9
ZSLNB20 08-8	0.8	0.4	0.5	8	0.77	50	4	6.1	9.3	9.8	10.3	10.7	11.3
ZSLNB20 08-10	0.8	0.4	0.5	10	0.77	50	4	5.4	11.4	12	12.5	12.9	13.7
ZSLNB20 10-2	1	0.5	0.8	2	0.96	50	4	9.9	2.9	3.1	3.3	3.5	4
ZSLNB20 10-3	1	0.5	0.8	3	0.96	50	4	8.9	4	4.3	4.5	4.8	5.3
ZSLNB20 10-4	1	0.5	0.8	4	0.96	50	4	8.1	5	5.4	5.7	6	6.5
ZSLNB20 10-5	1	0.5	0.8	5	0.96	50	4	7.4	6.1	6.5	6.9	7.2	7.8
ZSLNB20 10-6	1	0.5	0.8	6	0.96	50	4	6.8	7.2	7.7	8	8.4	9
ZSLNB20 10-7	1	0.5	0.8	7	0.96	50	4	6.3	8.3	8.8	9.2	9.5	10.2
ZSLNB20 10-8	1	0.5	0.8	8	0.96	50	4	5.9	9.3	9.9	10.3	10.7	11.3
ZSLNB20 10-9	1	0.5	0.8	9	0.96	50	4	5.5	10.4	11	11.4	11.8	12.5
ZSLNB20 10-10	1	0.5	0.8	10	0.96	50	4	5.2	11.5	12	12.5	12.9	13.7
ZSLNB20 10-12	1	0.5	0.8	12	0.96	55	4	4.6	13.6	14.2	14.7	15.2	15.9
ZSLNB20 10-14	1	0.5	0.8	14	0.96	55	4	4.2	15.7	16.4	16.9	17.4	18.5
ZSLNB20 10-16	1	0.5	0.8	16	0.96	55	4	3.8	17.8	18.5	19.1	19.6	21.2
ZSLNB20 10-18	1	0.5	0.8	18	0.96	60	4	3.5	19.9	20.7	21.3	21.8	23.8
ZSLNB20 10-20	1	0.5	0.8	20	0.96	60	4	3.3	22	22.8	23.4	24	26.5
ZSLNB20 12-4	1.2	0.6	1.1	4	1.15	50	4	7.9	5.1	5.4	5.7	6	6.5
ZSLNB20 12-6	1.2	0.6	1.1	6	1.15	50	4	6.6	7.2	7.7	8	8.4	9
ZSLNB20 12-8	1.2	0.6	1.1	8	1.15	50	4	5.7	9.4	9.9	10.3	10.7	11.3
ZSLNB20 12-10	1.2	0.6	1.1	10	1.15	50	4	5	11.5	12.1	12.5	12.9	13.7
ZSLNB20 12-12	1.2	0.6	1.1	12	1.15	55	4	4.5	13.6	14.2	14.7	15.2	15.9
ZSLNB20 14-8	1.4	0.7	1.3	8	1.34	50	4	5.5	9.4	9.9	10.3	10.7	11.3
ZSLNB20 14-12	1.4	0.7	1.3	12	1.34	55	4	4.3	13.6	14.2	14.7	15.2	15.9
ZSLNB20 14-16	1.4	0.7	1.3	16	1.34	55	4	3.5	17.8	18.5	19.1	19.6	21.2
ZSLNB20 15-4	1.5	0.75	1.35	4	1.44	50	4	7.7	5.1	5.4	5.7	6	6.5
ZSLNB20 15-6	1.5	0.75	1.35	6	1.44	50	4	6.4	7.3	7.7	8	8.4	9
ZSLNB20 15-8	1.5	0.75	1.35	8	1.44	50	4	5.4	9.4	9.9	10.3	10.7	11.3
ZSLNB20 15-10	1.5	0.75	1.35	10	1.44	50	4	4.7	11.5	12.1	12.5	12.9	13.7
ZSLNB20 15-12	1.5	0.75	1.35	12	1.44	55	4	4.2	13.6	14.2	14.7	15.2	15.9
ZSLNB20 15-14	1.5	0.75	1.35	14	1.44	55	4	3.8	15.7	16.4	16.9	17.4	18.5

▶ 적용 피삭재

○ : 적함 ◎ : 매우 적함

H		P			K	N			M	S
열처리강		탄소강	합금강	프리하든강	주철	동	흑연	알루미늄	스테인리스	내열합금
SKD61 ~HRc55	SKD11 HRc55~	~HB225	HB225 ~325	HRc30~50	~FCD500					
◎	◎		○	○						

ZSLNB20

2날 롱 넥 볼 엔드밀

Endmill

품목코드	DC	RE	APMX	LU	DN	OAL	DCONMS	BHTA	가공물 구배각별 유효길이				
	날경	반경 R	날장	유효장	유효경	전장	자루경	구배각	0.5°	1°	1.5°	2°	3°
ZSLNB20 15-16	1.5	0.75	1.35	16	1.44	55	4	3.4	17.8	18.5	19.1	19.6	21.1
ZSLNB20 15-20	1.5	0.75	1.35	20	1.44	60	4	2.9	22	22.8	23.4	24	-
ZSLNB20 16-8	1.6	0.8	1.4	8	1.54	50	4	5.3	9.4	9.9	10.3	10.7	11.3
ZSLNB20 16-10	1.6	0.8	1.4	10	1.54	50	4	4.6	11.5	12.1	12.5	12.9	13.7
ZSLNB20 16-12	1.6	0.8	1.4	12	1.54	55	4	4.1	13.6	14.2	14.7	15.2	15.9
ZSLNB20 16-16	1.6	0.8	1.4	16	1.54	55	4	3.3	17.8	18.5	19.1	19.6	21.1
ZSLNB20 16-20	1.6	0.8	1.4	20	1.54	60	4	2.8	22	22.8	23.4	24	-
ZSLNB20 18-8	1.8	0.9	1.6	8	1.73	50	4	5.1	9.4	9.9	10.3	10.7	11.3
ZSLNB20 18-12	1.8	0.9	1.6	12	1.73	55	4	3.9	13.7	14.3	14.7	15.2	15.9
ZSLNB20 18-16	1.8	0.9	1.6	16	1.73	55	4	3.1	17.9	18.6	19.1	19.6	21.1
ZSLNB20 18-20	1.8	0.9	1.6	20	1.73	60	4	2.6	22	22.8	23.4	24	-
ZSLNB20 20-3	2	1	1.7	3	1.92	50	4	8.3	4.1	4.4	4.6	4.8	5.2
ZSLNB20 20-4	2	1	3	4	1.92	50	4	7.3	5.2	5.5	5.8	6	6.5
ZSLNB20 20-6	2	1	3	6	1.92	50	4	5.8	7.3	7.7	8.1	8.4	9
ZSLNB20 20-8	2	1	3	8	1.92	50	4	4.9	9.5	9.9	10.3	10.7	11.3
ZSLNB20 20-10	2	1	3	10	1.92	50	4	4.2	11.6	12.1	12.6	12.9	13.6
ZSLNB20 20-12	2	1	3	12	1.92	55	4	3.7	13.7	14.3	14.8	15.2	15.9
ZSLNB20 20-14	2	1	3	14	1.92	55	4	3.2	15.8	16.4	16.9	17.4	18.5
ZSLNB20 20-16	2	1	3	16	1.92	55	4	2.9	17.9	18.6	19.1	19.6	-
ZSLNB20 20-18	2	1	3	18	1.92	60	4	2.7	20	20.7	21.3	21.8	-
ZSLNB20 20-20	2	1	3	20	1.92	60	4	2.4	22.1	22.8	23.4	24	-
ZSLNB20 20-22	2	1	3	22	1.92	60	4	2.3	24.1	24.9	25.6	26.3	-
ZSLNB20 20-25	2	1	3	25	1.92	65	4	2	27.3	28.1	28.8	-	-
ZSLNB20 20-30	2	1	3	30	1.92	70	4	1.7	32.4	33.4	34.2	-	-
ZSLNB20 20-35	2	1	3	35	1.92	75	4	1.5	37.6	38.6	-	-	-
ZSLNB20 20-40	2	1	3	40	1.92	80	4	1.4	42.8	43.8	-	-	-
ZSLNB20 25-10	2.5	1.25	4	10	2.4	50	4	3.4	11.6	12.1	12.6	13	13.6
ZSLNB20 25-16	2.5	1.25	4	16	2.4	55	4	2.3	17.9	18.6	19.1	19.6	-
ZSLNB20 25-20	2.5	1.25	4	20	2.4	60	4	1.9	22.1	22.8	23.5	-	-
ZSLNB20 30-8	3	1.5	4	8	2.88	55	6	6.2	9.6	10	10.4	10.7	11.3
ZSLNB20 30-10	3	1.5	4	10	2.88	55	6	5.5	11.7	12.2	12.6	13	13.6
ZSLNB20 30-13	3	1.5	4	13	2.88	60	6	4.6	14.8	15.4	15.9	16.3	17.1
ZSLNB20 30-16	3	1.5	4	16	2.88	60	6	4	18	18.6	19.1	19.6	21.1
ZSLNB20 30-18	3	1.5	4	18	2.88	60	6	3.6	20	20.7	21.3	21.8	23.7

Zamus Star
E-Star
U-Wing
Zamus Thunder
X-Star
S-Wing
A-Wing
Standard
Copper-Mate
Gra-Mate

▶ 적용 피삭재

○ : 적합 ◎ : 매우 적합

H		P			K	N			M	S
열처리강		탄소강	합금강	프리하든강	주철	동	흑연	알루미늄	스테인리스	내열합금
SKD61 ~HRc55	SKD11 HRc55~	~HB225	HB225 ~325	HRc30~50	~FCD500					
◎	◎		○	○						

ZSLNB20

2날 롱 넥 볼 엔드밀

Endmill

품목코드	DC	RE	APMX	LU	DN	OAL	DCONMS	BHTA	가공물 구배각별 유효길이				
	날경	반경 R	날장	유효장	유효경	전장	자루경	구배각	0.5°	1°	1.5°	2°	3°
ZSLNB20 30-20	3	1.5	4	20	2.88	65	6	3.4	22.1	22.9	23.5	24	26.4
ZSLNB20 30-25	3	1.5	4	25	2.88	70	6	2.8	27.3	28.2	28.8	29.9	-
ZSLNB20 30-30	3	1.5	4	30	2.88	75	6	2.5	32.5	33.4	34.3	35.9	-
ZSLNB20 30-35	3	1.5	4	35	2.88	80	6	2.2	37.7	38.7	40	41.9	-
ZSLNB20 40-10	4	2	5	10	3.9	55	6	4.5	11.6	12.1	12.5	12.9	13.5
ZSLNB20 40-13	4	2	5	13	3.9	60	6	3.6	14.7	15.3	15.8	16.2	17
ZSLNB20 40-16	4	2	5	16	3.9	60	6	3.1	17.9	18.5	19.1	19.5	20.9
ZSLNB20 40-20	4	2	5	20	3.9	65	6	2.5	22.1	22.8	23.4	23.9	-
ZSLNB20 40-25	4	2	5	25	3.9	70	6	2.1	27.3	28.1	28.8	29.8	-
ZSLNB20 40-30	4	2	5	30	3.9	75	6	1.8	32.4	33.4	34.2	-	-
ZSLNB20 40-35	4	2	5	35	3.9	80	6	1.6	37.6	38.6	39.9	-	-
ZSLNB20 40-40	4	2	5	40	3.9	80	6	1.4	42.8	43.8	-	-	-
ZSLNB20 40-45	4	2	5	45	3.9	90	6	1.2	47.9	49.1	-	-	-
ZSLNB20 40-50	4	2	5	50	3.9	100	6	1.1	53.1	54.5	-	-	-
ZSLNB20 50-20	5	2.5	6	20	4.9	65	6	1.4	22	22.8	-	-	-
ZSLNB20 50-25	5	2.5	6	25	4.9	70	6	1.2	27.2	28.1	-	-	-
ZSLNB20 50-30	5	2.5	6	30	4.9	75	6	1	32.4	-	-	-	-
ZSLNB20 50-35	5	2.5	6	35	4.9	80	6	0.8	42.8	-	-	-	-
ZSLNB20 50-40	5	2.5	6	40	4.9	90	6	0.7	42.8	-	-	-	-

Zamus Star

E-Star

U-Wing

Zamus Thunder

X-Star

S-Wing

A-Wing

Standard

Copper -Mate

Gra -Mate

▶ 적용 피삭재

○ : 적합 ◎ : 매우 적합

H		P			K	N			M	S
열처리강		탄소강	합금강	프리하든강	주철	동	흑연	알루미늄	스테인리스	내열합금
SKD61 ~HRc55	SKD11 HRc55~	~HB225	HB225 ~325	HRc30~50	~FCD500					
◎	◎		○	○						

ZSTNB20

2날 테이퍼 넥 볼 엔드밀

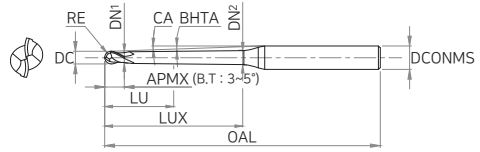

* R2 이상은 Back Draft Type이 아님

▶ 제품허용공차

날경(DC)		자루경
전 규격	0 ~ -0.015	h5



CARBIDE
AlTiN
2
30° HELIX
R ±0.005 R3 이하
R ±0.01 R3 초과
절삭조건 P.618

품목코드	DC	RE	APMX	LUX	CA	DN ¹	DN ²	OAL	DCONMS	LU	BHTA	가공물 구배각별 유효길이				
	날경	반경 R	날장	유효장	테이퍼각	유효경	대단경	전장	자루경	날경	구배각	0.5°	1°	1.5°	2°	3°
ZSTNB 2002-1-04	0.2	0.1	0.15	1	0.4	0.17	0.18	50	4	1.35	10.9	1.5	1.7	1.8	2	2.3
ZSTNB 2002-1.5-04	0.2	0.1	0.15	1.5	0.4	0.17	0.19	50	4	1.77	10.4	2	2.2	2.4	2.6	2.9
ZSTNB 2002-2-09	0.2	0.1	0.15	2	0.9	0.17	0.23	50	4	1.1	10.1	x	2.8	3.1	3.4	3.9
ZSTNB 2002-2.5-09	0.2	0.1	0.15	2.5	0.9	0.17	0.24	50	4	1.1	9.6	x	3.3	3.7	4	4.5
ZSTNB 2003-2-04	0.3	0.15	0.25	2	0.4	0.27	0.29	50	4	2.19	10	2.5	2.8	3	3.2	3.5
ZSTNB 2003-3-09	0.3	0.15	0.25	3	0.9	0.27	0.36	50	4	1.2	9.3	x	3.8	4.2	4.5	5.1
ZSTNB 2003-4-09	0.3	0.15	0.25	4	0.9	0.27	0.39	50	4	1.2	8.6	x	4.8	5.3	5.7	6.3
ZSTNB 2004-2-04	0.4	0.2	0.3	2	0.4	0.37	0.39	50	4	2.2	10	2.5	2.8	3	3.2	3.5
ZSTNB 2004-3-04	0.4	0.2	0.3	3	0.4	0.37	0.41	50	4	2.44	9.1	3.6	3.9	4.1	4.4	4.8
ZSTNB 2004-4-04	0.4	0.2	0.3	4	0.4	0.37	0.42	50	4	2.44	8.4	4.7	5.2	5.6	5.9	6.5
ZSTNB 2004-4-09	0.4	0.2	0.3	4	0.9	0.37	0.49	50	4	1.25	8.5	x	4.8	5.3	5.7	6.3
ZSTNB 2004-5-04	0.4	0.2	0.3	5	0.4	0.37	0.44	50	4	2.44	7.8	5.7	6.3	6.7	7.1	7.7
ZSTNB 2004-5-09	0.4	0.2	0.3	5	0.9	0.37	0.52	50	4	1.25	7.9	x	5.9	6.4	6.8	7.5
ZSTNB 2005-4-04	0.5	0.25	0.35	4	0.4	0.47	0.52	50	4	2.49	8.4	4.6	5	5.3	5.5	5.9
ZSTNB 2005-8-09	0.5	0.25	0.35	8	0.9	0.47	0.71	50	4	1.3	6.5	x	8.9	9.6	10.1	10.9
ZSTNB 2005-12-09	0.5	0.25	0.35	12	0.9	0.47	0.84	50	4	1.3	5.3	x	13	13.9	14.5	15.4
ZSTNB 20054-2-04	0.54	0.27	0.37	2	0.4	0.51	0.53	50	4	1.8	10	2.3	2.5	2.7	2.8	3
ZSTNB 20054-4-04	0.54	0.27	0.37	4	0.4	0.51	0.56	50	4	1.8	8.4	4.5	4.9	5.2	5.5	5.9
ZSTNB 20054-5-04	0.54	0.27	0.37	5	0.4	0.51	0.58	50	4	1.8	7.8	5.5	6	6.3	6.6	7.1
ZSTNB 20054-6-04	0.54	0.27	0.37	6	0.4	0.51	0.59	50	4	1.8	7.2	6.7	7.3	7.8	8.2	8.8

▶ 적용 피삭재

○ : 적합 ◎ : 매우 적합

H		P			K	N			M	S
열처리강		탄소강	합금강	프리하든강	주철	동	흑연	알루미늄	스테인리스	내열합금
SKD61 ~HRc55	SKD11 HRc55~	~HB225	HB225 ~325	HRc30~50	~FCD500					
◎	◎		○	○						

ZSTNB20

2날 테이퍼 넥 볼 엔드밀

Endmill

Zamus Star

E-Star

U-Wing

Zamus Thunder

X-Star

S-Wing

A-Wing

Standard

Copper-Mate

Gra-Mate

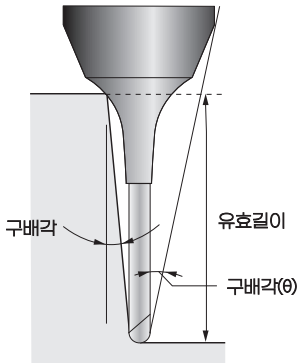

※ 표시된 유효길이는 공작물과의 간섭을 막기 위한 기본 값입니다.
가공환경의 적절한 제어가 필요합니다.

품목코드	DC	RE	APMX	LUX	CA	DN ¹	DN ²	OAL	DCONMS	LU	BHTA	가공용 구배각별 유효길이				
	날경	반경 R	날장	유효장	테이퍼각	유효경	대단경	전장	자루경	날경	구배각	0.5°	1°	1.5°	2°	3°
ZSTNB 20054-6.5-04	0.54	0.27	0.37	6.5	0.4	0.51	0.6	50	4	1.8	7	7.2	7.9	8.3	8.7	9.4
ZSTNB 20054-7-04	0.54	0.27	0.37	7	0.4	0.51	0.6	50	4	1.8	6.8	7.7	8.4	8.9	9.3	10
ZSTNB 2006-2-04	0.6	0.3	0.4	2	0.4	0.57	0.59	50	4	2.17	10	2.4	2.5	2.7	2.8	3
ZSTNB 2006-4-04	0.6	0.3	0.4	4	0.4	0.57	0.62	50	4	2.54	8.4	4.6	5	5.2	5.5	5.9
ZSTNB 2006-6-04	0.6	0.3	0.4	6	0.4	0.57	0.65	50	4	2.54	7.2	6.8	7.4	7.8	8.2	8.8
ZSTNB 2006-6-09	0.6	0.3	0.4	6	0.9	0.57	0.75	50	4	1.35	7.3	x	6.9	7.5	7.9	8.6
ZSTNB 2006-8-09	0.6	0.3	0.4	8	0.9	0.57	0.81	50	4	1.35	6.4	x	8.9	9.6	10.1	10.9
ZSTNB 2006-10-04	0.6	0.3	0.4	10	0.4	0.57	0.7	50	4	2.54	5.6	10.8	11.7	12.2	12.7	13.5
ZSTNB 2006-10-09	0.6	0.3	0.4	10	0.9	0.57	0.87	50	4	1.35	5.7	x	11	11.8	12.3	13.2
ZSTNB 2006-12-09	0.6	0.3	0.4	12	0.9	0.57	0.93	55	4	1.35	5.2	x	13	13.9	14.5	15.4
ZSTNB 2006-15-04	0.6	0.3	0.4	15	0.4	0.57	0.77	55	4	2.54	4.4	15.9	17	17.6	18.2	19.2
ZSTNB 2006-15-09	0.6	0.3	0.4	15	0.9	0.57	1.03	55	4	1.35	4.5	x	16.1	17.1	17.7	18.8
ZSTNB 2008-4-04	0.8	0.4	0.5	4	0.4	0.77	0.82	50	4	2.64	8.3	4.6	4.9	5.2	5.5	5.9
ZSTNB 2008-6-04	0.8	0.4	0.5	6	0.4	0.77	0.85	50	4	2.64	7.1	6.6	7.1	7.5	7.7	8.3
ZSTNB 2008-8-09	0.8	0.4	0.5	8	0.9	0.77	1.01	50	4	1.45	6.3	x	8.9	9.6	10.1	10.9
ZSTNB 2008-12-09	0.8	0.4	0.5	12	0.9	0.77	1.13	55	4	1.45	5	x	13	13.9	14.5	15.4
ZSTNB 2008-16-09	0.8	0.4	0.5	16	0.9	0.77	1.26	55	4	1.45	4.2	x	17.1	18.1	18.8	19.9
ZSTNB 2009-4-04	0.9	0.45	0.6	4	0.4	0.86	0.91	50	4	3.46	8.2	4.5	4.7	4.9	5.1	5.4
ZSTNB 2009-8-04	0.9	0.45	0.6	8	0.4	0.86	0.96	55	4	3.46	6.1	8.7	9.3	9.7	10	10.6
ZSTNB 2009-12-04	0.9	0.45	0.6	12	0.4	0.86	1.02	55	4	3.46	4.8	12.9	13.8	14.4	14.9	15.7

▶ 적용 피삭재

○ : 적합 ◎ : 매우 적합

H		P			K	N			M	S
열처리강		탄소강	합금강	프리하든강	주철	동	흑연	알루미늄	스테인리스	내열합금
SKD61 ~HRc55	SKD11 HRc55~	~HB225	HB225 ~325	HRc30~50	~FCD500					
◎	◎		○	○						

ZSTNB20

2날 테이퍼 넥 볼 엔드밀

Endmill

품목코드	DC	RE	APMX	LUX	CA	DN ¹	DN ²	OAL	DCONMS	LU	BHTA	가공물 구배각별 유효길이				
	날경	반경 R	날장	유효장	테이퍼각	유효경	대단경	전장	자루경	날경	구배각	0.5°	1°	1.5°	2°	3°
ZSTNB 2009-16-04	0.9	0.45	0.6	16	0.4	0.86	1.08	60	4	3.46	4	17	18	18.7	19.3	20.5
ZSTNB 2009-18-04	0.9	0.45	0.6	18	0.4	0.86	1.1	65	4	3.46	3.7	19.1	20.1	20.9	21.5	23.1
ZSTNB 2009-20-04	0.9	0.45	0.6	20	0.4	0.86	1.13	65	4	3.46	3.4	21.1	22.2	23	23.6	25.6
ZSTNB 2009-22-04	0.9	0.45	0.6	22	0.4	0.86	1.16	65	4	3.46	3.2	23.1	24.3	25.1	25.8	28.2
ZSTNB 2009-24-04	0.9	0.45	0.6	24	0.4	0.86	1.19	70	4	3.46	3	25.2	26.4	27.2	27.9	-
ZSTNB 2010-6-04	1	0.5	0.8	6	0.4	0.94	1.01	50	6	5.09	8.3	6.8	7.2	7.5	7.8	8.3
ZSTNB 2010-8-04	1	0.5	0.8	8	0.4	0.94	1.04	55	6	5.09	7.5	8.8	9.3	9.7	10	10.6
ZSTNB 2010-10-04	1	0.5	0.8	10	0.4	0.94	1.07	55	6	5.09	6.8	11	11.7	12.3	12.7	13.5
ZSTNB 2010-10-09	1	0.5	0.8	10	0.9	0.94	1.23	55	6	2.7	6.9	x	11.2	11.9	12.4	13.2
ZSTNB 2010-15-09	1	0.5	0.8	15	0.9	0.94	1.39	60	6	2.7	5.7	x	16.2	17.1	17.8	18.8
ZSTNB 2010-20-04	1	0.5	0.8	20	0.4	0.94	1.21	65	6	5.09	4.7	21.2	22.3	23	23.6	25.7
ZSTNB 2010-20-09	1	0.5	0.8	20	0.4	0.94	1.54	65	6	2.7	4.8	x	21.3	22.4	23.1	24.6
ZSTNB 2010-25-09	1	0.5	0.8	25	0.4	0.94	1.7	70	6	2.7	4.2	x	26.4	27.6	28.4	30.8
ZSTNB 2010-30-04	1	0.5	0.8	30	0.4	0.94	1.35	75	6	5.09	3.6	31.3	32.7	33.6	34.8	38.5
ZSTNB 2010-30-09	1	0.5	0.8	30	0.9	0.94	1.86	75	6	2.7	3.7	x	31.4	32.8	33.7	36.9
ZSTNB 2010-35-09	1	0.5	0.8	35	0.9	0.94	2.02	80	6	2.7	3.3	x	36.5	38	39	43.1
ZSTNB 2010-40-09	1	0.5	0.8	40	0.9	0.94	2.17	85	6	2.7	3	x	41.6	43.2	44.4	-
ZSTNB 2010-50-09	1	0.5	0.8	50	0.9	0.94	2.49	95	6	2.7	2.5	x	51.7	53.5	55.5	-
ZSTNB 2010-60-09	1	0.5	0.8	60	0.9	0.94	2.8	105	6	2.7	2.2	x	61.8	63.8	66.6	-
ZSTNB 2010-70-09	1	0.5	0.8	70	0.9	0.94	3.11	115	6	2.7	1.9	x	71.9	74	-	-
ZSTNB 2015-8-04	1.5	0.75	1.35	8	0.4	1.42	1.51	55	6	7.07	7.3	8.9	9.4	9.7	10	10.6
ZSTNB 2015-10-04	1.5	0.75	1.35	10	0.4	1.42	1.54	55	6	7.07	6.6	10.9	11.5	11.9	12.2	12.9
ZSTNB 2015-12-04	1.5	0.75	1.35	12	0.4	1.42	1.57	55	6	7.07	6	13	13.6	14	14.4	15.4
ZSTNB 2015-15-09	1.5	0.75	1.35	15	0.9	1.42	1.85	60	6	3.89	5.4	x	16.4	17.2	17.8	18.8
ZSTNB 2015-20-09	1.5	0.75	1.35	20	0.9	1.42	2.01	65	6	3.89	4.5	x	21.4	22.4	23.2	24.7
ZSTNB 2015-30-09	1.5	0.75	1.35	30	0.9	1.42	2.32	75	6	3.89	3.4	x	31.5	32.9	33.7	37
ZSTNB 2018-4-04	1.8	0.9	1.6	4	0.4	1.73	1.76	50	6	4.38	9.2	4.6	4.8	4.9	5.1	5.4
ZSTNB 2018-8-04	1.8	0.9	1.6	8	0.4	1.73	1.82	50	6	6.61	7.1	8.6	9	9.2	9.4	10.2
ZSTNB 2018-12-04	1.8	0.9	1.6	12	0.4	1.73	1.88	55	6	6.61	5.8	12.9	13.5	14	14.4	15.4
ZSTNB 2018-16-04	1.8	0.9	1.6	16	0.4	1.73	1.93	60	6	6.61	4.9	17	17.7	18.3	18.7	20.5
ZSTNB 2018-20-04	1.8	0.9	1.6	20	0.4	1.73	1.99	65	6	6.61	4.3	21.2	22.3	23	23.6	25.6
ZSTNB 2018-24-04	1.8	0.9	1.6	24	0.4	1.73	2.04	65	6	6.61	3.8	25.3	26.5	27.3	27.9	30.8
ZSTNB 2018-28-04	1.8	0.9	1.6	28	0.4	1.73	2.1	70	6	6.61	3.4	29.4	30.6	31.5	32.4	35.9
ZSTNB 2018-32-04	1.8	0.9	1.6	32	0.4	1.73	2.15	70	6	6.61	3	33.4	34.8	35.7	37.1	-

Zamus Star
E-Star
U-Wing
Zamus Thunder
X-Star
S-Wing
A-Wing
Standard
Copper-Mate
Gra-Mate

▶ 적용 피삭재

○ : 적합 ◎ : 매우 적합

H		P			K	N			M	S
열처리강		탄소강	합금강	프리하든강	주철	동	흑연	알루미늄	스테인리스	내열합금
SKD61 ~HRc55	SKD11 HRc55~	~HB225	HB225 ~325	HRc30~50	~FCD500					
◎	◎		○	○						

ZSTNB20 2날 테이퍼 넥 볼 엔드밀

Endmill

품목코드	DC	RE	APMX	LUX	CA	DN ¹	DN ²	OAL	DCONMS	LU	BHTA	가공물 구배각별 유효길이				
	날경	반경 R	날장	유효장	테이퍼각	유효경	대단경	전장	자루경	날경	구배각	0.5°	1°	1.5°	2°	3°
ZSTNB 2018-36-04	1.8	0.9	1.6	36	0.4	1.73	2.21	75	6	6.61	2.8	37.5	38.9	39.9	41.7	-
ZSTNB 2018-38-04	1.8	0.9	1.6	38	0.4	1.73	2.24	80	6	6.61	2.7	39.5	41	42	44	-
ZSTNB 2018-40-04	1.8	0.9	1.6	40	0.4	1.73	2.27	80	6	6.61	2.6	41.5	43.1	44.2	46.3	-
ZSTNB 2020-8-04	2	1	1.7	8	0.4	1.92	2.01	50	6	7.42	7	8.7	9	9.2	9.5	10.2
ZSTNB 2020-12-04	2	1	1.7	12	0.4	1.92	2.06	55	6	7.42	5.7	13	13.6	14	14.4	15.4
ZSTNB 2020-16-04	2	1	1.7	16	0.4	1.92	2.12	60	6	7.42	4.8	17	17.7	18.3	18.7	20.5
ZSTNB 2020-20-04	2	1	1.7	20	0.4	1.92	2.18	65	6	7.42	4.1	21.3	22.3	23	23.6	25.6
ZSTNB 2020-20-09	2	1	1.7	20	0.9	1.92	2.5	65	6	4.24	4.2	x	21.4	22.4	23.2	24.6
ZSTNB 2020-25-09	2	1	1.7	25	0.9	1.92	2.65	65	6	4.24	3.6	x	26.5	27.7	28.5	30.8
ZSTNB 2020-30-04	2	1	1.7	30	0.4	1.92	2.32	70	6	7.42	3.1	31.4	32.7	33.6	34.8	38.5
ZSTNB 2020-30-09	2	1	1.7	30	0.9	1.92	2.81	70	6	4.24	3.2	x	31.6	32.9	33.7	36.9
ZSTNB 2020-35-09	2	1	1.7	35	0.9	1.92	2.97	75	6	4.24	2.8	x	36.6	38	39	-
ZSTNB 2020-40-04	2	1	1.7	40	0.4	1.92	2.46	80	6	7.42	2.5	41.5	43.1	44.2	46.3	-
ZSTNB 2020-40-09	2	1	1.7	40	0.9	1.92	3.12	80	6	4.24	2.6	x	41.7	43.2	44.5	-
ZSTNB 2020-50-09	2	1	1.7	50	0.9	1.92	3.44	90	6	4.24	2.1	x	51.5	53.5	55.5	-
ZSTNB 2020-60-09	2	1	1.7	60	0.9	1.92	3.75	100	6	4.24	1.8	x	61.9	63.8	-	-
ZSTNB 2020-70-09	2	1	1.7	70	0.9	1.92	4.07	110	6	4.24	1.8	x	72	74.1	-	-
ZSTNB 2030-8-04	3	1.5	2.5	8	0.4	2.86	2.94	50	6	8.5	6.3	8.8	9.1	9.3	9.5	10.3
ZSTNB 2030-16-04	3	1.5	2.5	16	0.4	2.86	3.05	55	6	12.52	4.1	17.2	17.8	18.3	18.7	20.6
ZSTNB 2030-20-04	3	1.5	2.5	20	0.4	2.86	3.1	60	6	12.52	3.4	21.2	22	22.6	23.3	25.7
ZSTNB 2030-30-04	3	1.5	2.5	30	0.4	2.86	3.24	70	6	12.52	2.5	31.6	32.8	33.7	34.9	-
ZSTNB 2030-30-09	3	1.5	2.5	30	0.9	2.86	3.72	70	6	6.95	2.6	x	31.8	33	33.8	-
ZSTNB 2030-40-04	3	1.5	2.5	40	0.4	2.86	3.38	80	6	12.52	2	41.7	43.2	44.3	-	-
ZSTNB 2030-40-09	3	1.5	2.5	40	0.9	2.86	4.04	80	6	6.95	2	x	41.9	43.3	-	-
ZSTNB 2030-50-09	3	1.5	2.5	50	0.9	2.86	4.35	90	6	6.95	1.7	x	52	53.6	-	-
ZSTNB 2030-60-09	3	1.5	2.5	60	0.9	2.86	4.67	100	6	6.95	1.4	x	62.1	-	-	-
ZSTNB 2030-70-09	3	1.5	2.5	70	0.9	2.86	4.98	110	6	6.95	1.2	x	72.1	-	-	-
ZSTNB 2040-20-10	4	2	8	20	1	3.86	4.28	70	8	12.01	5	20.5	21.6	22.3	22.8	23.5
ZSTNB 2040-30-10	4	2	8	30	1	3.86	4.63	80	8	12.01	3.51	22	31.6	32.5	33.2	34.16
ZSTNB 2040-40-10	4	2	8	40	1	3.86	4.98	90	8	12.01	2.7	22	42	43.4	44.3	-
ZSTNB 2040-50-10	4	2	8	50	1	3.86	5.33	100	8	12.01	2.2	22	52	53.6	54.7	-
ZSTNB 2040-60-10	4	2	8	60	1	3.86	5.68	110	8	12.01	1.9	22	62	63.8	-	-
ZSTNB 2050-30-10	5	2.5	10	30	1	4.86	5.56	80	8	14.01	2.8	25.5	31.7	32.6	33.2	-
ZSTNB 2050-40-10	5	2.5	10	40	1	4.86	5.91	90	8	14.01	2.1	25.5	41.7	42.8	43.5	-

▶ 적용 피삭재

○ : 적합 ◎ : 매우 적합

H		P			K	N			M	S
열처리강		탄소강	합금강	프리하든강	주철	동	흑연	알루미늄	스테인리스	내열합금
SKD61 ~HRc55	SKD11 HRc55~	~HB225	HB225 ~325	HRc30~50	~FCD500					
◎	◎		○	○						

ZSTNB20

2날 테이퍼 넥 볼 엔드밀

Endmill

품목코드	DC	RE	APMX	LUX	CA	DN ¹	DN ²	OAL	DCONMS	LU	BHTA	가공물 구배각별 유효길이				
	날경	반경 R	날장	유효장	테이퍼각	유효경	대단경	전장	자루경	날경	구배각	0.5°	1°	1.5°	2°	3°
ZSTNB 2050-60-10	5	2.5	10	60	1	4.86	6.61	110	8	14.01	1.5	25.5	62.1	-	-	-
ZSTNB 2060-30-10	6	3	12	30	1	5.86	6.49	80	8	16.01	1.9	29	31.8	32.6	-	-
ZSTNB 2060-40-10	6	3	12	40	1	5.86	6.84	90	8	16.01	1.5	29	41.8	-	-	-
ZSTNB 2060-50-10	6	3	12	50	1	5.86	7.19	100	8	16.01	1.2	29	51.8	-	-	-
ZSTNB 2060-60-10	6	3	12	60	1	5.86	7.54	110	10	16.01	1.9	29	62.2	63.9	-	-
ZSTNB 2060-70-10	6	3	12	70	1	5.86	7.89	120	10	16.01	1.7	29	72.2	74.1	-	-
ZSTNB 2060-80-10	6	3	12	80	1	5.86	8.23	130	10	16.01	1.5	29	82.2	-	-	-
ZSTNB 2080-50-10	8	4	14	50	1	7.86	9.12	110	10	18.01	1.2	32	51.9	-	-	-
ZSTNB 2080-60-10	8	4	14	60	1	7.86	9.47	120	10	18.01	1	32	-	-	-	-
ZSTNB 2080-70-10	8	4	14	70	1	7.86	9.82	130	10	18.01	0.9	32	-	-	-	-
ZSTNB 2080-80-10	8	4	14	80	1	7.86	10.16	140	12	18.01	1.5	32	82.3	-	-	-
ZSTNB 2100-60-10	10	5	18	60	1	9.86	11.33	130	12	22.01	1.1	39	62.1	-	-	-
ZSTNB 2100-75-10	10	5	18	75	1	9.86	11.85	140	12	22.01	0.9	39	-	-	-	-

Zamus Star

E-Star

U-Wing

Zamus Thunder

X-Star

S-Wing

A-Wing

Standard

Copper-Mate

Gra-Mate

▶ 적용 피삭재

○ : 적합 ◎ : 매우 적합

H		P			K	N			M	S
열처리강		탄소강	합금강	프리하든강	주철	동	흑연	알루미늄	스테인리스	내열합금
SKD61 ~HRC55	SKD11 HRC55~	~HB225	HB225 ~325	HRC30~50	~FCD500					
◎	◎		○	○						

ZSTNB30

3날 테이퍼 넥 볼 엔드밀

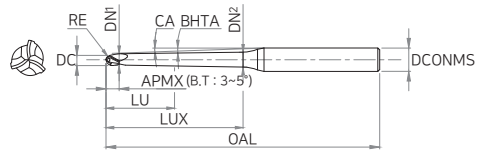

* R2 이상은 Back Draft Type이 아님

▶ 제품허용공차

날경(DC)		자루경
전 규격	0 ~ -0.015	h5

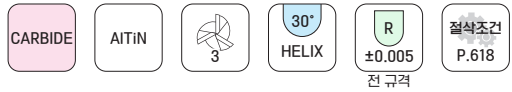
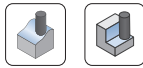

품목코드	DC	RE	APMX	LUX	CA	DN ¹	DN ²	OAL	DCONMS	LU	BHTA	가공물 구배각별 유효길이				
	날경	반경 R	날장	유효장	테이퍼각	유효경	대단경	전장	자루경	날경	구배각	0.5°	1°	1.5°	2°	3°
ZSTNB 3020-8-04	2	1	1.7	8	0.4	1.92	2.01	50	6	7.42	7	8.7	9	9.2	9.5	10.2
ZSTNB 3020-12-04	2	1	1.7	12	0.4	1.92	2.06	55	6	7.42	5.7	13	13.6	14	14.4	15.4
ZSTNB 3020-16-04	2	1	1.7	16	0.4	1.92	2.12	60	6	7.42	4.8	17	17.7	18.3	18.7	20.5
ZSTNB 3020-20-04	2	1	1.7	20	0.4	1.92	2.18	65	6	7.42	4.1	21.3	22.3	23	23.6	25.6
ZSTNB 3020-20-09	2	1	1.7	20	0.9	1.92	2.5	65	6	4.24	4.2	x	21.4	22.4	23.2	24.6
ZSTNB 3020-25-09	2	1	1.7	25	0.9	1.92	2.65	65	6	4.24	3.6	x	26.5	27.7	28.5	30.8
ZSTNB 3020-30-04	2	1	1.7	30	0.4	1.92	2.32	70	6	7.42	3.1	31.4	32.7	33.6	34.8	38.5
ZSTNB 3020-30-09	2	1	1.7	30	0.9	1.92	2.81	70	6	4.24	3.2	x	31.6	32.9	33.7	36.9
ZSTNB 3020-35-09	2	1	1.7	35	0.9	1.92	2.97	75	6	4.24	2.8	x	36.6	38	39	-
ZSTNB 3020-40-04	2	1	1.7	40	0.4	1.92	2.46	80	6	7.42	2.5	41.5	43.1	44.2	46.3	-
ZSTNB 3020-40-09	2	1	1.7	40	0.9	1.92	3.12	80	6	4.24	2.6	x	41.7	43.2	44.5	-
ZSTNB 3020-50-09	2	1	1.7	50	0.9	1.92	3.44	90	6	4.24	2.1	x	51.8	53.5	55.5	-
ZSTNB 3020-60-09	2	1	1.7	60	0.9	1.92	3.75	100	6	4.24	1.8	x	61.9	63.8	-	-
ZSTNB 3020-70-09	2	1	1.7	70	0.9	1.92	4.07	110	6	4.24	1.6	x	72	74.1	-	-
ZSTNB 3030-8-04	3	1.5	2.5	8	0.4	2.86	2.94	50	6	8.5	6.3	8.8	9.1	9.3	9.5	10.3
ZSTNB 3030-16-04	3	1.5	2.5	16	0.4	2.86	3.05	55	6	12.52	4.1	17.2	17.8	18.3	18.7	20.6
ZSTNB 3030-20-04	3	1.5	2.5	20	0.4	2.86	3.1	60	6	12.52	3.4	21.2	22	22.6	23.3	25.7
ZSTNB 3030-30-04	3	1.5	2.5	30	0.4	2.86	3.24	70	6	12.52	2.5	31.6	32.8	33.7	34.9	-
ZSTNB 3030-30-09	3	1.5	2.5	30	0.9	2.86	3.72	70	6	6.95	2.6	x	31.8	33	33.8	-
ZSTNB 3030-40-04	3	1.5	2.5	40	0.4	2.86	3.38	80	6	12.52	2	41.7	43.2	44.3	-	-

▶ 적용 피삭재

○ : 적합 ◎ : 매우 적합

H		P			K	N			M	S
열처리강		탄소강	합금강	프리하든강	주철	동	흑연	알루미늄	스테인리스	내열합금
SKD61 ~HRc55	SKD11 HRc55~	~HB225	HB225 ~325	HRc30~50	~FCD500					
◎	◎		○	○						

ZSTNB30

3날 테이퍼 넥 볼 엔드밀

Endmill

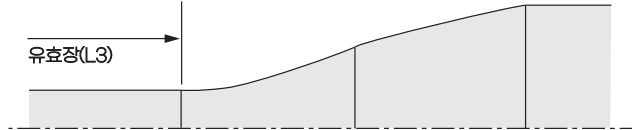
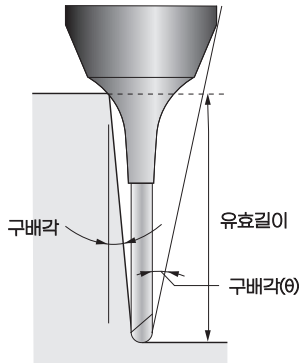

※ 표시된 유효길이는 공작물과의 간섭을 막기 위한 기본 값입니다.
가공환경의 적절한 제어가 필요합니다.

품목코드	DC	RE	APMX	LUX	CA	DN ¹	DN ²	OAL	DCONMS	LU	BHTA	가공물 구배각별 유효길이				
	날경	반경 R	날장	유효장	테이퍼각	유효경	대단경	전장	자루경	날경	구배각	0.5°	1°	1.5°	2°	3°
ZSTNB 3030-40-09	3	1.5	2.5	40	0.9	2.86	4.04	80	6	6.95	2	x	41.9	43.3	-	-
ZSTNB 3030-50-09	3	1.5	2.5	50	0.9	2.86	4.35	90	6	6.95	1.7	x	52	53.6	-	-
ZSTNB 3030-60-09	3	1.5	2.5	60	0.9	2.86	4.67	100	6	6.95	1.4	x	62.1	-	-	-
ZSTNB 3030-70-09	3	1.5	2.5	70	0.9	2.86	4.98	110	6	6.95	1.2	x	72.1	-	-	-
ZSTNB 3040-20-10	4	2	8	20	1	3.86	4.28	70	8	12.01	5	20.5	21.6	22.3	22.8	23.5
ZSTNB 3040-30-10	4	2	8	30	1	3.86	4.63	80	8	12.01	3.6	22	31.6	32.5	33.2	34.1
ZSTNB 3040-40-10	4	2	8	40	1	3.86	4.98	90	8	12.01	2.7	22	42	43.4	44.3	-
ZSTNB 3040-50-10	4	2	8	50	1	3.86	5.33	100	8	12.01	2.2	22	52	53.6	54.7	-
ZSTNB 3040-60-10	4	2	8	60	1	3.86	5.68	110	8	12.01	1.9	22	62	63.8	-	-
ZSTNB 3050-30-10	5	2.5	10	30	1	4.86	5.56	80	8	14.01	2.8	25.5	31.7	32.6	33.2	-
ZSTNB 3050-40-10	5	2.5	10	40	1	4.86	5.91	90	8	14.01	2.1	25.5	41.7	42.8	43.5	-
ZSTNB 3050-60-10	5	2.5	10	60	1	4.86	6.61	110	8	12.52	1.5	25.5	62.1	-	-	-

Zamus Star

E-Star

U-Wing

Zamus Thunder

X-Star

S-Wing

A-Wing

Standard

Copper-Mate

Gra-Mate

▶ 적용 피삭재

○ : 적합 ◎ : 매우 적합

H		P			K	N			M	S
열처리강		탄소강	합금강	프리하든강	주철	동	흑연	알루미늄	스테인리스	내열합금
SKD61 ~HRc55	SKD11 HRc55~	~HB225	HB225 ~325	HRc30~50	~FCD500					
◎	◎		○	○						